



**CODONICS**<sup>®</sup>

*We bring the future into focus*

# **Horizon<sup>®</sup> Multi-media Dry Imager**

---

## **Starter Manual**

Codonics<sup>®</sup> Catalog Number H-START-EN  
February 2022  
Version 3.1.1 USB Flash Drive  
Version 2.2.1 ZIP Disk

Codonics, Inc.  
17991 Englewood Drive  
Middleburg Heights, OH 44130 USA  
440.243.1198 Phone  
440.243.1334 Fax  
Email [info@codonics.com](mailto:info@codonics.com)  
[www.codonics.com](http://www.codonics.com)

Copyright © 2004-2022 by Codonics, Inc. All rights reserved, worldwide. Printed in the U.S.A. Part Number 905-042-101.

No part of this document may be copied or reproduced in any form by any means without prior written consent of Codonics, Inc., 17991 Englewood Dr., Middleburg Heights, Ohio 44130 U.S.A.

Although every effort has been made to ensure the accuracy of this document, Codonics, Inc. assumes no responsibility for any errors that may appear. Codonics, Inc. makes no commitment to update nor to keep current the information contained in this document.

Horizon Patents: [www.codonics.com/ip/patents](http://www.codonics.com/ip/patents)

Horizon, DirectVista, ChromaVista, the Codonics logo, and “We bring the future into focus” are registered trademarks, and Codonics, Variable Multiformating, VMF, Fixed Multiformating, FMF, Medical Color Matching, MCM, SlideMaker, and Bracketing are trademarks of Codonics, Inc.

Windows and Windows NT are registered trademarks of Microsoft Corporation.

PostScript is a registered trademark of Adobe Systems Incorporated.

Apple and Macintosh are trademarks of Apple Computer, Inc., registered in the U.S. and other countries.

UNIX is a registered trademark of The Open Group.

Linux is a registered trademark of Linus Torvalds.

Zip is a registered trademark of Iomega Corporation.

StuffIt is a trademark of Aladdin Systems, Inc.

PKZIP is a registered trademark of PKWARE, Inc.

Intel is a registered trademark of Intel Corporation or its subsidiaries in the United States and other countries.

All other registered and unregistered trademarks are the property of their respective owners.

European Authorized Representative:

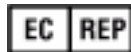

CEpartner4U  
Esdoornlaan 13,  
3951DB Maarn  
The Netherlands



[www.cepartner4u.com](http://www.cepartner4u.com)

# Contents

## Preface

Manual Conventions .....	-vii
Bulleted Lists .....	-vii
Numbered Steps .....	-vii
Control Panel Navigation .....	-viii
Control Panel Keys .....	-viii
Control Panel Menu Options .....	-viii
Notes .....	-viii
Cautions and Warnings .....	-viii
Purpose and Scope .....	-ix
Product Information .....	-x
Disposal Requirements .....	-xi
Warnings and Limitations of Use .....	-xii
Location of Safety and Compliance Labels .....	-xii
Voltage Warning .....	-xiii
Laser Warning .....	-xiv
Temperature Warning .....	-xv
Compliance .....	-xv
Serial Number, Configuration, Date Code, and Modification Codes ....	-xvi
ESD Caution .....	-xvii
Potential for Radio Frequency Interference on Imager Operation .....	-xvii
Potential for Radio and Television Interference .....	-xviii
Safety Precautions .....	-xix
Location Precautions .....	-xxi
Cleaning Precautions .....	-xxii
Media .....	-xxii
File Transfer via FTP and LPR .....	-xxiv
Color Management .....	-xxiv

Image Scaling .....	-xxiv
Hardware Variations.....	-xxv
Indications for Use .....	-xxv

## **Chapter 1: Setting Up the Imager**

Preparing for Installation.....	1-1
Installing the Imager .....	1-2
Connecting the Ethernet Cable .....	1-6
Powering On the Imager—First Time .....	1-8
Cleaning the Platen Roller .....	1-9
Network Settings—Simple Network.....	1-10
Specifying the Imager’s IP Address .....	1-11
Determining an IP Address.....	1-11
Specifying the Imager’s IP Address at the Control Panel.....	1-12
Specifying IP Addresses for Other Devices on the Network .....	1-14
Loading Media .....	1-15
Preparing the Imager for Shipment .....	1-15

## **Chapter 2: Basic Imager Operations**

Horizon Imager Components.....	2-1
Powering the Imager On and Off.....	2-3
Powering On the Imager .....	2-3
Observing the Imager’s Operating Status in the Status Screen.....	2-4
Common Cassette Status Messages .....	2-5
Color Ribbon Status.....	2-6
Powering Off the Imager .....	2-7
Understanding the Control Panel .....	2-8
Control Panel Indicators.....	2-9
Alert and Fault Messages and the Fault Tone .....	2-10
Control Panel Display.....	2-10
Main Menu .....	2-10

## Chapter 3: Media Handling and Storage

Overview.....	3-1
Supply Slots and Cassettes .....	3-1
Viewing the Status of a Supply Slot.....	3-3
Inserting or Changing Cassettes .....	3-4
Handling and Storing Media .....	3-6
Break-Off Leaders (ChromaVista Only) .....	3-6
Changing the Ribbon (ChromaVista).....	3-7
Ordering Media.....	3-10

## Chapter 4: Printing from DICOM Applications

Introduction to DICOM.....	4-1
DICOM Conformance Statement .....	4-2
Configuring the DICOM Application.....	4-2
Sending a DICOM Print Job .....	4-3
Specifying the Media Type and Size.....	4-3
Using Job Settings Files with DICOM.....	4-3
Categories of Job Settings .....	4-4
Specifying a Job Settings File from a DICOM User Application.....	4-4
Hierarchy of Settings Used by the Horizon Imager .....	4-5

## Chapter 5: Printing from Windows via PostScript

Introduction to PostScript .....	5-2
Printing from Windows Applications .....	5-2
Notes About Changing PostScript Parameters.....	5-2
Changing Horizon PostScript Parameters—Windows 2000 and XP.....	5-3

## Chapter 6: Default Print Job Settings

Changing the Default Settings.....	6-2
Changing the Default Media Type and Size.....	6-2
Changing the Default User Settings.....	6-3

## **Chapter 7: Preventive Maintenance**

Recommended Maintenance Schedule .....	7-1
Horizon Cleaning Kits.....	7-2
Cleaning the Thermal Print Head and Platen Roller.....	7-3
Cleaning the Pick Tires.....	7-7

## **Chapter 8: Film Calibration**

## **Chapter 9: Troubleshooting**

Sources of Status Information .....	9-1
Control Panel .....	9-1
Error Log .....	9-1
Online Help for Displayed Messages .....	9-1
Troubleshooting Tables .....	9-2
Status Message Tables .....	9-8
Common Cassette Status Messages.....	9-8
Color Ribbon Status .....	9-9
Clearing a Sheet Jam .....	9-9
Clearing a Jam from a Cassette.....	9-12
Clearing a Jam from the Printing Area.....	9-14
Reinstalling Media Guides .....	9-17
Purging Print Jobs .....	9-19
Contacting Technical Support .....	9-20

## **Appendix A: Specifications**

## **Appendix B: System Job Settings Files**

## **Index**

# Preface

## Manual Conventions

### Bulleted Lists

Bullets are used to display a list of nonprocedural items. For example:

The control panel contains:

- A display panel
- Keys
- Indicators

### Numbered Steps

The  icon indicates the beginning of a procedure. The steps in a procedure are numbered. For example:



To access the Main Menu and scroll through menu options

1. Press the  key.

The Main Menu displays on the control panel. The selector arrow (  ) automatically points to the first menu option.

2. To scroll through the menu options, press the  and  keys.

The selector arrow (  ) moves up and down through the list. The bottom portion of the control panel display shows a message associated with the currently selected menu option.

## **Control Panel Navigation**

*Menu paths* are used in some procedures instead of documenting every step needed to navigate to a specific menu option. For example:

From the Main Menu, select the following options:

**Default Media**  
**Grayscale**  
**DV Film Blue**

## **Control Panel Keys**

Control panel keys are shown in small black ovals to resemble the actual keys, for example, “Press the  key.”

## **Control Panel Menu Options**

Control panel menu options are shown in bold type, for example, “Select the **Gamma** menu option.”

## **Notes**

Notes contain additional information related to a topic or procedure. For example:



**NOTE:** *If your network is managed by a network administrator or an information technology (IT) department, it would be considered a complex network. You should have the responsible person perform any network-related administrative tasks.*

## **Cautions and Warnings**

Cautions alert you to actions or situations that could cause harm to equipment or data. For example:



**CAUTION** Any changes you make to the imager default settings will also affect prints made by other users. Use caution when changing default settings.



Warnings alert you to actions or situations that could result in personal injury. For example:



**WARNING** With the imager cover open, touch only those internal components that are colored green (except for the pick tires).

## **Purpose and Scope**

Refer to this Starter Manual for procedures on how to perform the most common imager operations, including:

- Setting up the imager
- Loading media
- Sending print jobs from DICOM Print Service Class-compliant applications running on imaging devices or image viewing workstation
- Changing the imager's default image and sheet settings
- Adjusting the appearance of printed images for user preference
- Performing preventive maintenance
- Performing film calibration
- Troubleshooting common problems



**NOTE:** Some features and functions described here may not apply to older versions of the software.

This Starter Manual is intended to be as simple and straightforward as possible for the everyday user. If you need more detailed or more technical information on a feature or topic, or wish to perform more advanced operations, refer to the *Horizon Imager Technical Manual* (Catalog no. HORIZON-MNLT) and the *Horizon Imager User's Manual* (Catalog no. HORIZON-MNLU). The Technical Manual serves as a companion document to this manual.

## **Product Information**

For technical assistance with the Horizon, call Codonics Technical Support at the following number:

**Phone:** +1.440.243.1198  
**Toll Free:** 800.444.1198 (USA only)

Technical Support is available anytime. Technical Support is also available online via email and the Codonics web site:

**Email:** [support@codonics.com](mailto:support@codonics.com)  
**Web Site:** [www.codonics.com](http://www.codonics.com)

General product information can also be requested by sending email to:

**Email:** [info@codonics.com](mailto:info@codonics.com)

Please include your postal mailing address and telephone number in the email message. Basic product information is returned via email unless otherwise requested.

# **Disposal Requirements**

Disposal of this product shall be in accordance with all applicable laws and regulations in effect at the locality at the time of disposal.

## **European Disposal Requirements**

Codonics imagers and electronic accessory devices are not to be discarded or recycled; rather they are to be returned to the manufacturer. Contact Codonics directly or by the link provided for the latest information concerning:

- Identification of the country specific Importer/Distributor/Producer
- Product return and treatment of our electronic products

Manufacturer: Codonics Incorporated  
17991 Englewood Drive  
Middleburg Heights, OH 44130 USA  
Phone: +1.440.243.1198  
Fax: +1.440.243.1334  
Email: WEEE@codonics.com  
www.codonics.com

Codonics imagers and electronic accessory devices bearing this symbol are subject to European Directive on Waste Electrical and Electronic Equipment (WEEE) 2002/96/EC, amended by Directive 2003/108/EC. The EN 50419 symbol indicates separate collection and return required.



# Warnings and Limitations of Use

## Location of Safety and Compliance Labels

The following figure shows the locations of the imager's safety and compliance labels.

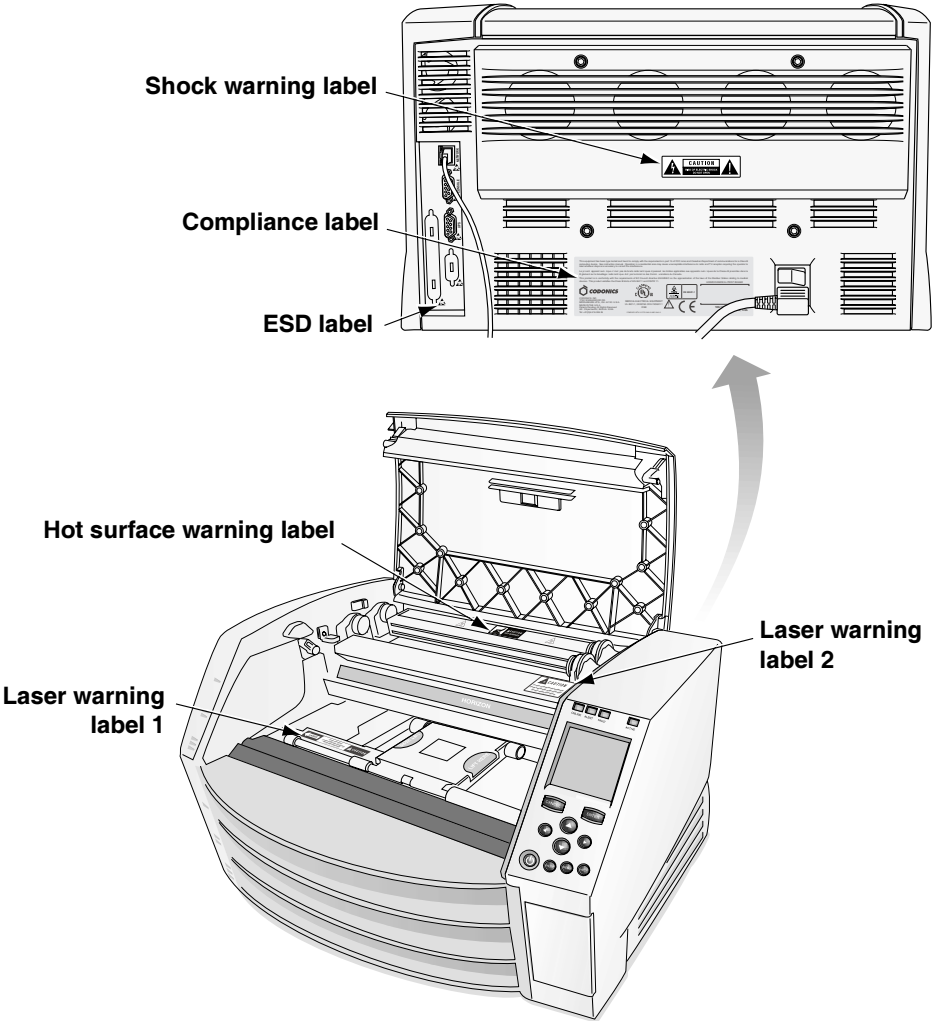

## **Voltage Warning**

The exclamation point within an equilateral triangle and person reading a manual symbol are intended to alert the user to the presence of important operating and maintenance (servicing) instructions in the literature accompanying this device.



**NO USER-SERVICEABLE PARTS INSIDE. REFER SERVICING TO QUALIFIED SERVICE PERSONNEL. REMOVAL OF LABELS, COVERS, OR ENCASMENT FASTENERS VOIDS THE WARRANTY.**

**THIS APPARATUS MUST BE ELECTRICALLY GROUNDED.**

**TO PREVENT FIRE OR SHOCK HAZARD, DO NOT EXPOSE THIS IMAGER TO RAIN OR MOISTURE.**

**EQUIPMENT IS NOT TO BE USED AS A COMPONENT OF A LIFE SUPPORT SYSTEM.** Life support devices or systems are devices or systems that support or sustain life, and whose failure to perform can be reasonably expected to result in a significant injury or death to a person. A critical component is any component of a life support device or system whose failure to perform can be reasonably expected to cause the failure of the life support device or system, or to affect its safety or effectiveness.

## Laser Warning

The Horizon imager uses a laser to read barcode information on the media cassettes. The laser module is a 650 – 670-nm device of 1.26 mW or less. As such, it has been found to comply with the 21 CFR 1040.10 and 1040.11 and IEC 60825 laser standards as a low power Class 1 device.

For safety reasons, the laser is turned on only for a short time when a cassette is inserted. Still, one should use caution and never stare at the laser beam, should avoid exposure to the laser, and should never override any of the interlocks and safety mechanisms. These measures are taken for your protection.



**WARNING** Use of controls or adjustments to the performance of procedures other than those specified in this manual may result in hazardous radiation exposure.

The laser apertures are marked with a single label, shown below. There are three apertures that correspond to the three cassette locations, one for each, on the same side of the Horizon imager as this label.



Safety interlocks are marked by the following label. They are located on the same side of the Horizon imager as this label.

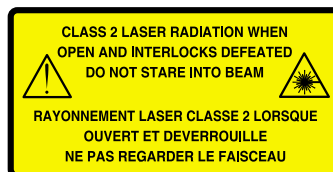

The locations of the two laser labels are shown in the figure on page xii.

## Temperature Warning

Because the Horizon imager is a thermal print device, the surface of the thermal print head heat sink gets hot. Avoid directly touching any components not colored green when accessing the interior of the imager if the imager has been printing. (During some preventative maintenance tasks, you will be touching internal components with cleaning pads or swabs.)

The temperature warning label is shown below.



## Compliance

Codonics is in compliance with various regulations, of which details are listed in Appendix A.

The Compliance label, which is affixed at the back of the imager, is shown below.

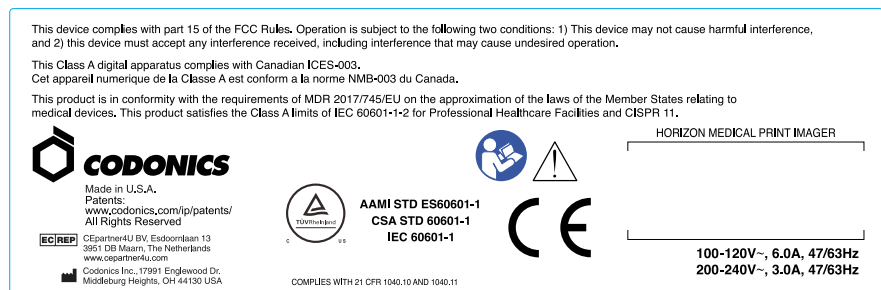

## **Serial Number, Configuration and Modification Codes**

The Serial number label is placed onto the Compliance label. It includes the following information:

- The serial number (SN), which uniquely identifies the unit.
- The configuration number (CNFG), which details the build configuration.
- The modifications codes, which are to the right of the CNFG number and are a series of 20 numbers. When any of these numbers are blocked out, that identifies a modification that was made to the unit.

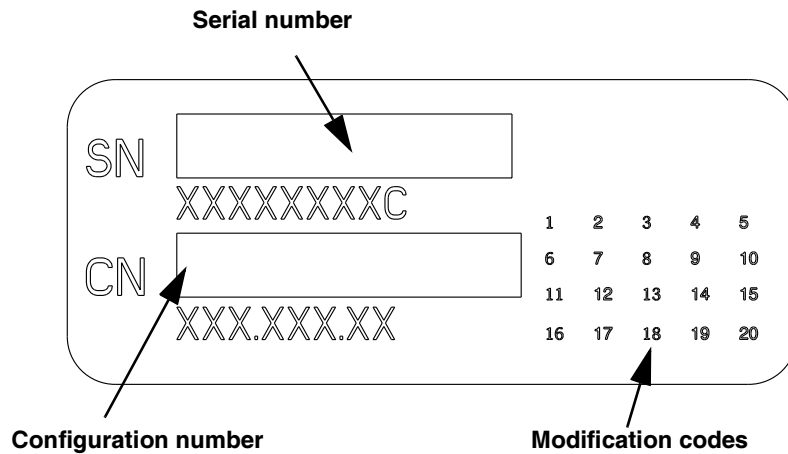



## **ESD Caution**

Connections to other pieces of equipment are made at the rear of the Horizon imager. These connectors are marked with a precautionary ESD warning symbol, as shown below. Do not touch any of the pins of these connectors. When making connections to the imager, it is best done while the imager is plugged in but not powered on. ESD may cause erratic behavior of the imager when powered on. Should this occur, power to the imager may have to be cycled. It is recommended that all staff involved in making connections to the imager be aware of these ESD precautions.

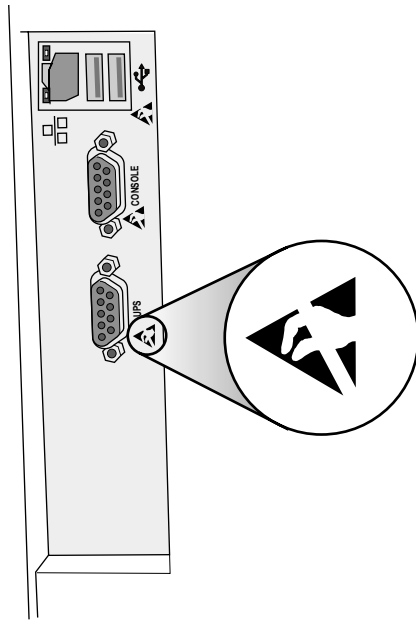

## **Potential for Radio Frequency Interference on Imager Operation**

Both portable and mobile RF communications equipment can affect medical electrical equipment, including the Horizon imager. Keep such RF communications equipment out of the immediate area.

## **Potential for Radio and Television Interference**

The Horizon imager generates and uses radio frequency energy, and if not installed and used properly, that is, in strict accordance with the manufacturer's instructions, may cause interference to radio and television reception. It has been type tested and found to comply with Class A emission limits for a computing device in accordance with the specifications in Subpart J of Part 15 of FCC Rules, which are designed to provide reasonable protection against such interference when operating in a commercial environment. Operation of the equipment in a residential area is likely to cause interference, in which case the user, at his own expense, will be required to take whatever measures may be appropriate to correct the interference. If your imager does cause interference to radio or television reception, you are encouraged to try to correct the interference by one or more of the following measures:

- Reorient the receiving antenna
- Relocate the imager with respect to the receiver

If necessary, you should consult Codonics technical support or an experienced radio/television technician for additional suggestions. You may find the following booklet prepared by the Federal Communications Commission helpful: *How to Identify and Resolve Radio-TV Interference Problems*. This booklet is available from the U.S. Government Printing Office, Washington, D.C. 20402, Stock No. 004-000-00345-4.

*Le présent appareil numérique n'émet pas de bruits radio-électriques dépassant les limites applicables aux appareils numériques de la Classe A prescrites dans le Règlement sur le brouillage radioélectrique édicté par le ministère des Communications du Canada.*

This product is in conformity with the requirements of EC Council regulation MDR 2017/745/EU on the approximation of the laws of the Member States relating to medical devices. This product satisfies the Class A limits of IEC60601-1-2 and CISPR 11. A declaration of conformity with the requirements of the regulation has been signed by the Director of Quality Assurance and Regulatory Affairs.

## ***Safety Precautions***

- Never connect this imager to any outlet or power supply that has a voltage or frequency different than that specified on the rear of the imager.
- When servicing the imager, always power it off using the  (power) key at the control panel, then turn the rocker switch in the back to the **0** (off) position, then unplug the imager.
- Damage to the power cord may cause fire or shock hazard. When unplugging the power cord, hold it by the plug only and remove the plug carefully.
- If the power cord needs to be replaced, replace it only with another Codonics power cord manufactured specifically for your imager's power configuration.
- If the imager is smoking or making unusual sounds, power off and unplug the imager immediately.
- Do not insert foreign objects of any kind into the imager; doing so can constitute a safety hazard and cause extensive damage.

- Do not place any liquid containers on the imager. If, for some reason, liquid seeps into the imager, power off the imager and unplug the power cord from the source outlet. If used without corrective measures, the imager may be damaged.
- Do not use the imager near flammable gases.
- With the imager top cover open or the receive trays removed, touch only those internal components that are colored green (except for the pick tires). Remove rings, ties, jewelry, and other items, and tie back hair, so that they do not fall into or get caught in the imager.

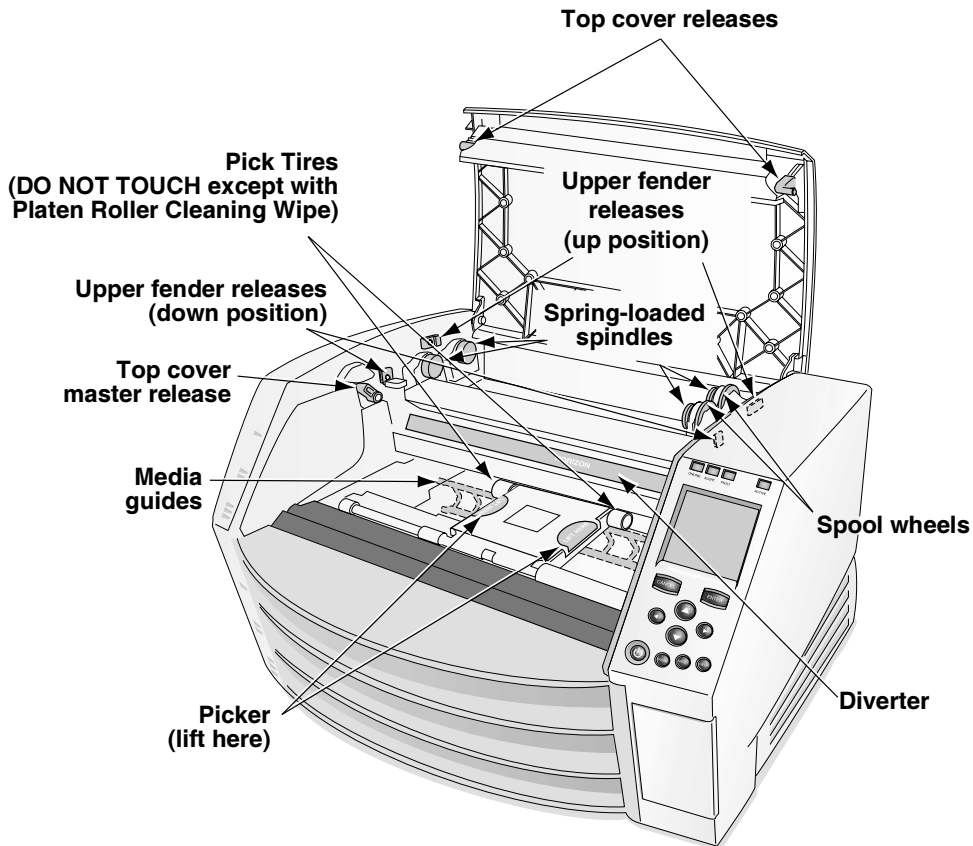

***Internal Components That Are Colored Green (called out in the illustration) Are Safe to Touch (except for the pick tires)***

## Location Precautions

- The imager's operating ambient temperature range is 15–30°C (59–86°F), with a relative humidity of 10%–80%, non-condensing.
- If the imager is moved quickly from an extremely cold place to a warmer one, condensation is likely to form. Do not use the imager if condensation has formed. Wait until the condensation has evaporated. You can speed up the evaporation time by moving the imager to a dryer location.
- Ventilation slots and holes are provided on the sides and rear of the imager. Place the imager on a hard level surface and locate it at least 10 cm (4 in.) from walls to ensure proper ventilation.



**CAUTION** Adequate ventilation is required for proper operation of the imager.

- Do not place imager in a high humidity or high dust area. Airborne dirt particles can cause image quality problems. Avoid placing the imager in areas where ventilation ducts, open doors, or frequent passers-by might expose the imager and media to high levels of debris.
- Do not locate the imager in hot-springs areas where hydrogen sulfide and acidic ions are likely to be generated.
- Do not locate the imager where there are oily fumes and vapors.
- Do not locate the imager in direct sunlight.
- Do not locate imager near sources of high RF energy.
- Do not locate the imager where it might be subject to jarring or vibrations, such as a table or desk in a high-traffic area. Jarring and vibrations can affect the print quality of images.

## **Cleaning Precautions**

- Many plastic components are used in the imager's construction. Coat flecking and deformation is likely to occur if the imager is wiped with chemical dusters, benzene, thinners, insecticides, or other solvents. Rubber and PVC materials left in contact with the imager for extended times will cause damage. Never use petroleum-based solutions or abrasive cleaners.
- To clean the imager cover, first power off the imager using the **⏻** (power) key at the control panel, then turn the rocker switch in the back to the **0** (off) position, then unplug the imager. Clean the cover with a soft cloth slightly moistened with a mild soap and water solution. Allow the cover to completely dry before operating the imager again.

## **Media**

- For **ChromaVista**<sup>®</sup> color prints, the consumed ribbon contains facsimiles of any patient images printed to **ChromaVista** color sheets. Therefore, you must properly dispose of or destroy consumed ribbon to ensure the confidentiality of patient images.
- The optical density of reflective and transmissive prints have a nominal range of:  $D_{min} = 0.10$  OD (reflective), 0.11 OD (transmissive) to  $D_{max} = 2.10$  OD (reflective), 3.0 OD (transmissive). Actual optical densities may vary based on media variations and on the instrument being used to measure density. For example, **DirectVista**<sup>®</sup> Clear film may have a lower  $D_{min}$  and  $D_{max}$  than **DirectVista** Blue film.

- The Horizon imager includes a built-in densitometer. The built-in densitometer is designed to produce consistent prints by compensating for variation from one film cassette to another and one imager to another. For applications that require absolute control of the maximum density, the results should be checked against a bench-top commercial densitometer. The internal densitometer can be calibrated to a desktop unit. See the *Horizon Imager Technical Manual* for more information.
- **DirectVista** media is optimized for grayscale prints, while **ChromaVista** is optimized for color prints. If **ChromaVista** is not giving you satisfactory results with grayscale images, you may want to consider using **DirectVista** media for those applications.
- Media variations between different production lots may produce subtle differences in image quality and color. These variations most often occur in color ribbons and are characterized as a slight color hue in grayscale images.
- Codonics film media is designed to be viewed using a light box suitable for viewing medical diagnostic images.
- Codonics paper media is designed to be viewed under cool-white, fluorescent light. Spectral differences and intensity variations in the viewing light sources can change the apparent color of images printed on paper.
- Printed images that are subject to prolonged exposure to sunlight, ultraviolet light, or extreme heat may degrade in image quality. (For example, printed sheets should not be stored in an automobile on a sunny day.) Precautions should be used to avoid prolonged direct exposure.

## ***File Transfer via FTP and LPR***

- Different users who share a user name when transferring files to the imager may cause unpredictable and erroneous printed output. The imager associates information with the user name. Each user should have a unique user name when connecting to the imager via FTP and LPR.

## ***Color Management***

- Image settings—including gamma, contrast, Dmax, saturation, and MCM™ (Medical Color Matching™)—are intended to compensate for differences that may occur between image acquisition and image printing. These filters allow you to accurately render the final printed image. You should use care when applying these filters to avoid over compensation.
- The Default User Settings set at the control panel will potentially affect prints made by all users. Use caution when changing the default settings.

## ***Image Scaling***

- Scaling an image will filter the original image data and add or remove information, which may affect the accuracy of the final printed image. The amount of information added or removed will also vary with the magnitude of the scale factor applied. This can also affect the accuracy of the final printed image. You should be aware of the properties and limitations of each scaling algorithm and select the appropriate algorithm for the task.



## **Hardware Variations**

- Components used in the imager may vary, causing differences in image quality. The thermal process of producing a print utilizes many components that are calibrated to provide consistency between imagers. There are subtle differences between imagers that can cause print variations. These differences usually apply to thermal print head calibration. Other factors such as age, usage, heat, mechanical wear, and shipping can affect image color and quality.

## **Indications for Use**

The Codonics, Inc., family of Horizon imagers produces radiological quality, hardcopy output. They can produce color prints on dye-diffusion film and paper, and grayscale prints on direct thermal film and paper. They are designed to convert digital image data from a host computer into hardcopy prints.

Film prints are suitable for diagnostic use when viewed on a light box designed for such purposes. Color film prints, and color and grayscale paper prints, have the quality, texture, and feel of standard photographic materials. All Horizon imagers create prints electronically, without optics, wet chemicals, or a separate fusing process.

The exact media types and sizes supported will vary, depending on the specific model purchased.



# 1

## **Setting Up the Imager**

### **Preparing for Installation**

To prepare for the Horizon imager installation, review the following guidelines and requirements:



**CAUTION** Make sure that the table or printer stand can support the weight of the imager [approximately 66.7 kg (147 lbs) with receive trays and three full supply cassettes installed].

- Select a location for the imager that meets the requirements described in “Location Precautions” on page xxi in the Preface.
- It is recommended that you use a UPS (uninterruptible power supply) to protect the imager from voltage spikes and power outages.
- Contact field service representatives of any imaging devices or image viewing workstations that will be used with the imager, to ensure that they are available during the imager’s installation to assist with setup and help troubleshoot potential problems.

# Installing the Imager

The Horizon imager comes stored in two boxes:

- The imager is stored in the larger box.
- The receive trays, power cord, manuals, technical briefs, and other accessories are stored in the smaller box.



**WARNING** The imager is heavy. To avoid injury, use two people to unpack and position the imager.



To install the imager

1. Move the imager box close to the desired location.
2. Open the imager box and follow the instructions printed on the box insert.
3. Lift the imager from the box and position it at the desired location.
4. Open the Smart Card access door at the lower right front of the imager and make sure that the Smart Card is fully seated in its slot.

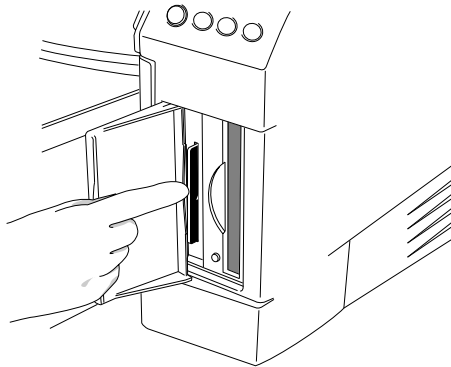

**Smart Card in slot—Horizon  
with Zip drive**

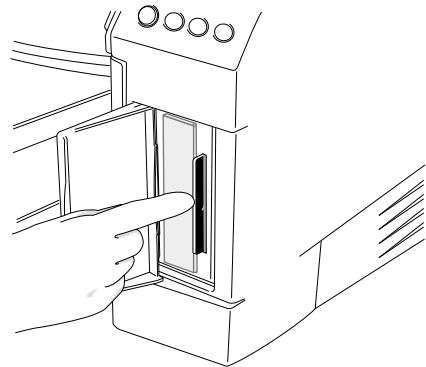

**Smart Card in slot—Horizon  
with no Zip drive**



7. Open the top cover by pressing any of the green releases.

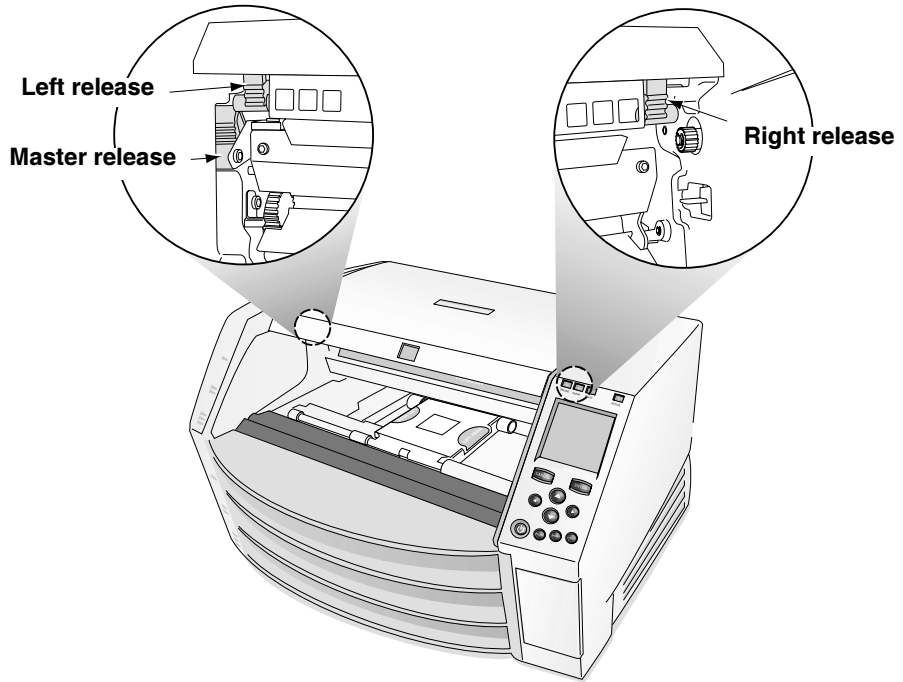

8. Remove any packing material inside the imager.

- Using a print head cleaning wipe included in the Accessory box, gently clean the imager basement of any debris.



**CAUTION** Do not scratch or nick the sheet metal. Scratches and nicks in the basement will damage the printed side of **ChromaVista** sheets.

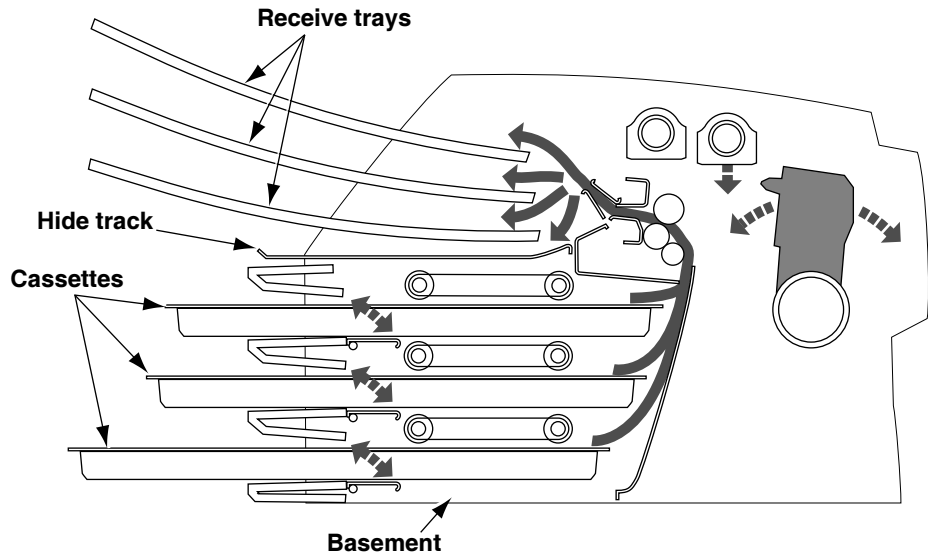

***Cross-Section of Imager, Showing Location of Hide Track and Basement (with receive trays and cassettes installed)***

- Remove the receive trays from their box.
- Using a platen roller wipe included in the Accessory box, clean the receive trays of any dust or debris.



**NOTE:** Save the imager box and all packing material. You must reinsert any packing material and use the original box to ship the imager. Refer to “Preparing the Imager for Shipment” on page 1-15 for more information.

12. Place the receive trays into the imager.

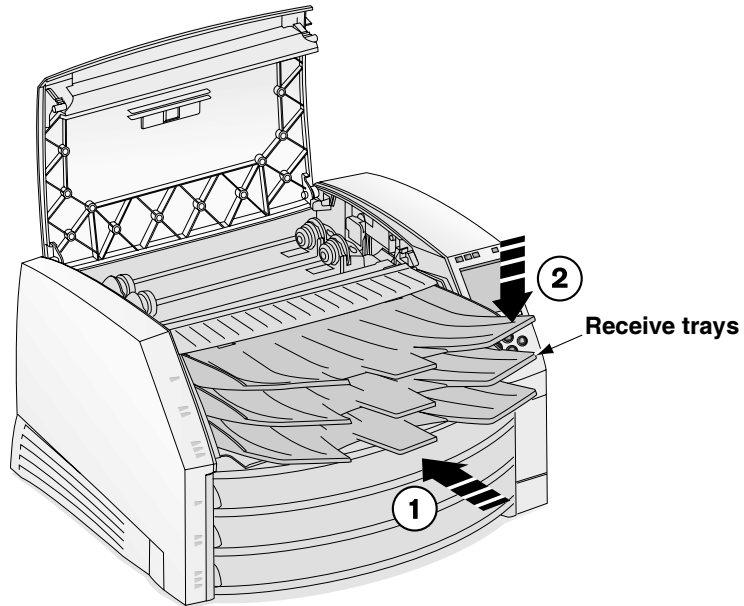

13. Close the top cover.

## **Connecting the Ethernet Cable**

The Horizon imager supports the following network cables and hubs:



- Category 5, RJ-45 [also referred to as unshielded twisted pair (UTP)] network patch cables and crossover cables
- 10/100/1000 Base-T Ethernet hubs



**CAUTION** Make sure that the imager is powered off before connecting the Ethernet cable. For information about powering the imager on and off, refer to “Powering the Imager On and Off” on page 2-3.



To connect the Ethernet cable to the imager

1. Locate the Ethernet cable jack at the back of the imager and insert the Ethernet cable.

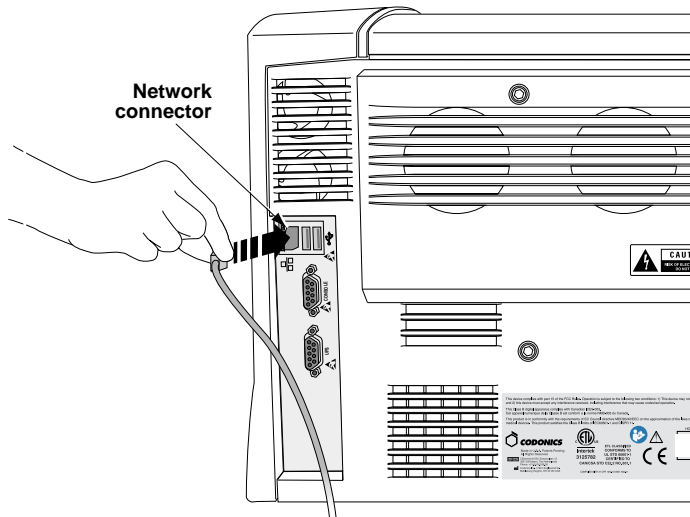

**CAUTION** Do not touch any of the connector pins.

2. Connect the other end of the Ethernet cable to the Ethernet hub or to the workstation’s Ethernet jack.



**NOTE:** When connecting the imager to only one workstation without the use of a hub, you must use a special Ethernet cable, called a crossover cable. Optionally, you could still connect the imager and the single workstation using two standard Ethernet patch cables and a hub. This would allow for future expansion of the network.

# Powering On the Imager—First Time



To power on  
the imager

1. Press the power rocker switch to the **1** (on) position.

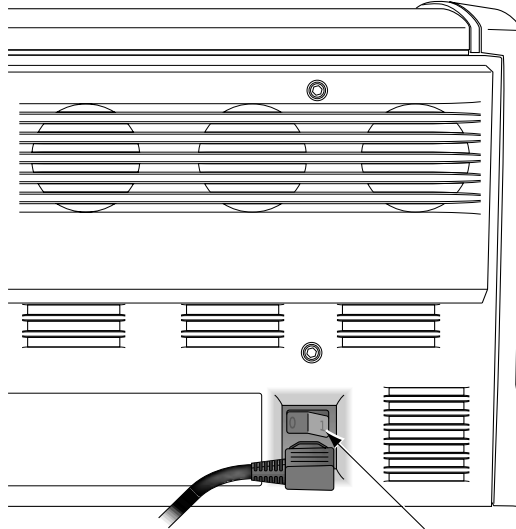

Power rocker switch

2. Press the  (power) key at the control panel.



**NOTE:** Always use the  key at the control panel to power on/off the imager. The power rocker switch at the back of the imager should always be in the **1** (on) position, unless the imager is being serviced or moved.

The control panel display shows startup messages as the imager initializes. When the Status screen displays (shown below), the imager is ready to receive images.

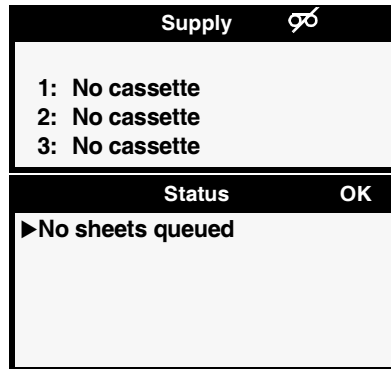

## ***Cleaning the Platen Roller***

Clean the platen roller after powering the imager on for the first time. Refer to “Cleaning the Thermal Print Head and Platen Roller” on page 7-3.

# Network Settings—Simple Network

This topic explains how to add the imager to a simple network. For adding the imager to a complex network, refer to the *Horizon Imager Technical Manual*.



**NOTE:** If your network is managed by a network administrator or an information technology (IT) department, it would be considered a complex network. You should have the responsible person perform any network-related administrative tasks.

By *simple network*, we mean a local-area network (LAN) that is *not* connected to another LAN or wide-area network (WAN).

A simple network typically comprises several devices connected by Ethernet UTP cable through an Ethernet hub. It could also be simpler yet—a workstation or imaging device connected directly to the Horizon imager using an Ethernet crossover cable.

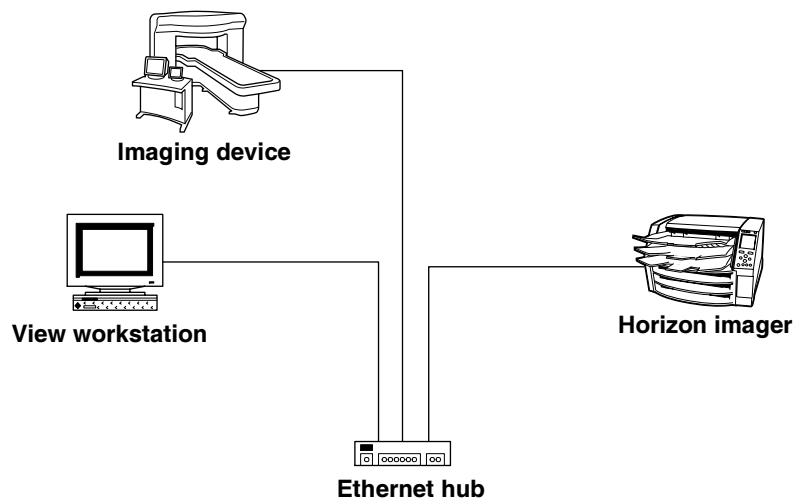

**Simple Network with Ethernet Hub**

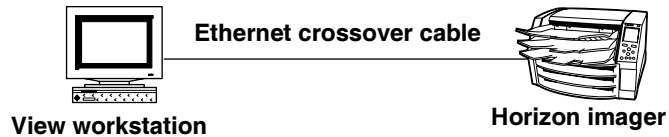

### ***Simple Network with Ethernet Crossover Cable***

In addition to the physical cabling connection, you must define an IP (Internet Protocol) address for the imager.

## ***Specifying the Imager's IP Address***

The required IP address uniquely identifies the imager on the network.

### ***Determining an IP Address***

Make sure that device IP addresses within this network are unique.



**NOTE:** *If devices on this network **do** have to communicate with devices on other networks, it is part of a complex network. For more information about configuring the Horizon imager in a complex network, refer to the Horizon Imager Technical Manual.*

IP addresses have the format  $x.x.x.x$ , where  $x$  is a value from 0 to 255. One series of IP addresses, 192.168. $x.x$ , has been reserved by internet convention for self-contained networks. You assign the last two parts in the address. So, you might assign the IP addresses as follows:

- 192.168.1.200 to the Horizon imager
- 192.168.1.201 to an image viewing workstation on the network
- 192.168.1.202 to a second workstation
- 192.168.1.203 to an imaging device

And so on.

## Specifying the Imager's IP Address at the Control Panel



**NOTE:** For a simple network, you will only need to define the imager's base IP address. You can leave all other network settings for the imager at their default values.



**NOTE:** For instructions on how to use the imager's control panel and menus, refer to Chapter 2.





**NOTE:** After entering the base IP address, note that the imager will reboot once you exit the menus so that the software can be properly updated with the new value.



To specify the imager's IP address

1. At the imager's control panel, press and hold the  key, and while holding it press the  key.

The Main Menu with administrative options displays.

2. Use the  and  keys to move the selector arrow to **Network Settings**.

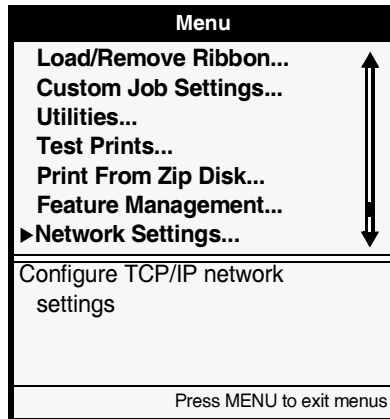

3. With the **Network Settings** option selected, press the **ENTER** key.

The Network Settings menu displays. Note that the current settings are displayed in square brackets.

Network Settings
<b>Network Settings</b> Speed [Auto Sense]... ▶Addresses... Reset Network Settings
Set network addresses of this Imager.
Press MENU to exit menus

4. Select the **Addresses** option, then press the **ENTER** key.

The Network Addresses menu displays. Note that bold square *change* brackets are displayed around the first IP address octet value of the Base IP Address. The bracketed portion of the address is the portion that can currently be changed.

Network Addresses
<b>Base IP Address:</b> [0].0.0.0
<b>Gateway:</b> 0.0.0.0
<b>Subnet Mask:</b> 255.255.255.0
<b>Number of IP Addresses:</b> 1
<b>Set base IP address</b> <b>Old value:</b> 0.0.0.0 UP/DOWN to alter octet, LEFT/RIGHT to change octets
Press MENU to exit menus



**NOTE:** The Horizon imager can have more than one IP address assigned to it. For more information about assigning multiple IP addresses, refer to the Horizon Imager Technical Manual.

5. To change the first octet, press the ▲ or ▼ key until the number you want is displayed.  
Hold these keys to cycle through numbers.
6. To select the next octet, press the ► key. (Press the ◀ key to return to the previous octet.)
7. Repeat steps 5 and 6 until all four octets in the Base IP Address have been defined. To save, press the **ENTER** key.



**NOTE:** To exit the Network Addresses menu without saving your changes, press the **CANCEL** key. The previous menu in the hierarchy displays.

8. Press the **CANCEL** or ◀ key to leave the Network Settings menu.  
A message states that the imager will automatically reboot when you press the **MENU** key to exit the Main Menu.
9. Press the **ENTER** key to acknowledge the message.
10. When you are finished specifying the IP address and want to exit the Main Menu, press the **MENU** key.

Because the base IP address was defined, the imager reboots so that it can be identified properly on the network.



**NOTE:** You can reset the network settings to their default values at any time by selecting the **Reset Network Settings** option in the Network Settings menu.

## **Specifying IP Addresses for Other Devices on the Network**

Just as you did for the Horizon imager, you must specify the IP addresses for each of the other devices on the network. Refer to the documentation or online help that comes with the device for specific instructions.

For more information about IP addressing conventions, refer to the *Horizon Imager Technical Manual*.



## Loading Media

After setting the imager's IP address, you can load media cassettes and, optionally, load a ribbon to support color prints. For more information about how to load media, refer to "Inserting or Changing Cassettes" on page 3-4 and "Changing the Ribbon (ChromaVista)" on page 3-7.

## Preparing the Imager for Shipment

If you have to ship the imager for any reason, you must use the original imager box and packing materials. If you do not have the original box and packing materials, contact your Codonics representative.



To prepare the imager for shipment

1. If a ribbon is in the imager, remove it. For more information, refer to "Changing the Ribbon (ChromaVista)" on page 3-7.
2. Make sure the top cover is closed and the receive trays are inserted.



**NOTE:** The top cover must be closed **and** the receive trays must be inserted for the thermal print head to park. If either the top cover is open or the receive trays are not inserted, the imager will display a message indicating that it cannot be shut down until the condition is corrected.

3. Power off the imager. For more information, refer to "Powering Off the Imager" on page 2-7.
4. Remove the receive trays.

5. Open the top cover by pressing any of the green releases.

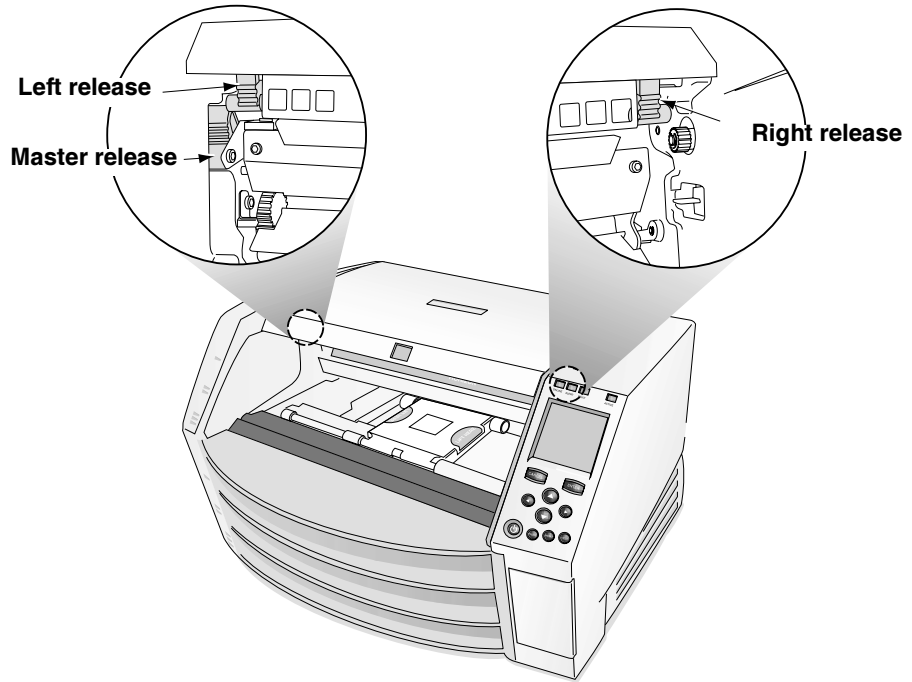

6. Make sure that the thermal print head has parked. The thermal print head should be secure with no wobble.

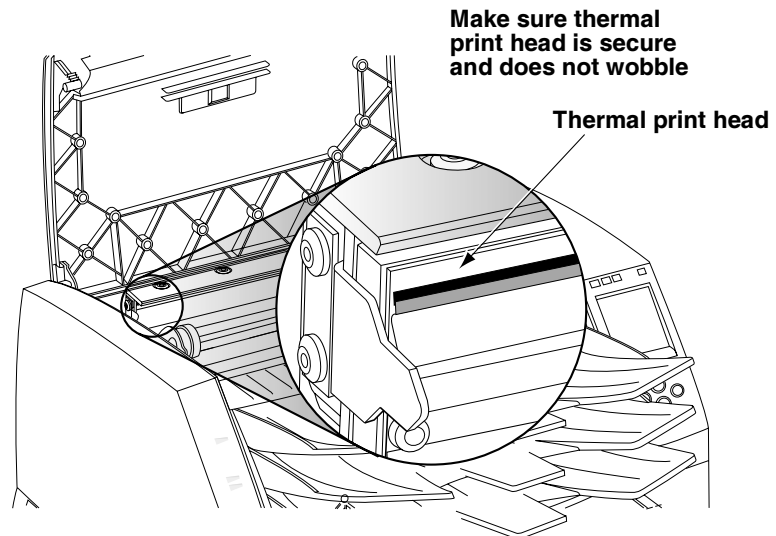



**CAUTION** If the thermal print head is not parked, power on the imager, then repeat steps 2 and 3 to properly power off the imager so that it does park.

7. Look down into the imager just in front of the thermal print head and make sure that the ribbon carriage is fully down to the bottom of the imager. (The ribbon carriage should have lowered during power off.)

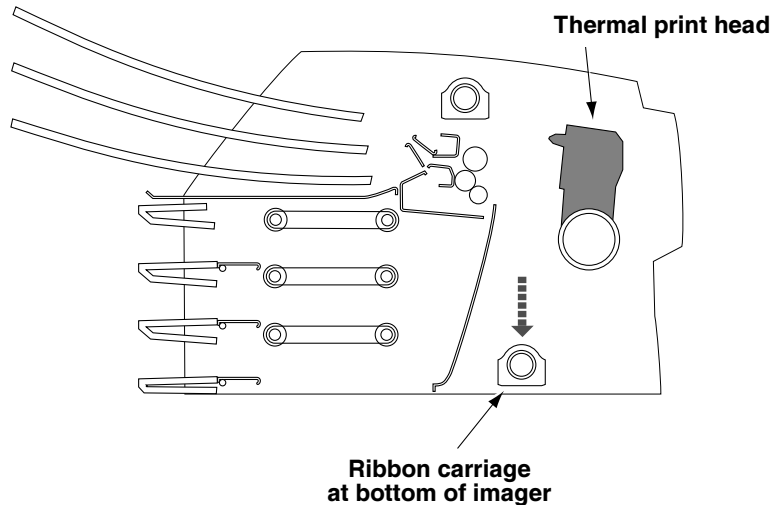

### ***Cross-Section View of Imager***



**NOTE:** If the ribbon carriage is not fully down, you can use the foam stabilizer to push it down. The stabilizer is shown in the first panel of the repacking illustration on the box insert. The ribbon carriage does not move easily, but it is safe to apply moderate pressure to force it all the way down.



**CAUTION** Push the ribbon carriage down slowly. Forcing it down too quickly may damage the carriage.

8. Replace the packing materials into the imager, close the top cover, and repack the imager into its original box. Refer to the box insert for illustrated instructions.



# 2

## Basic Imager Operations

### Horizon Imager Components

The following illustrations show the names and locations of the main imager components.

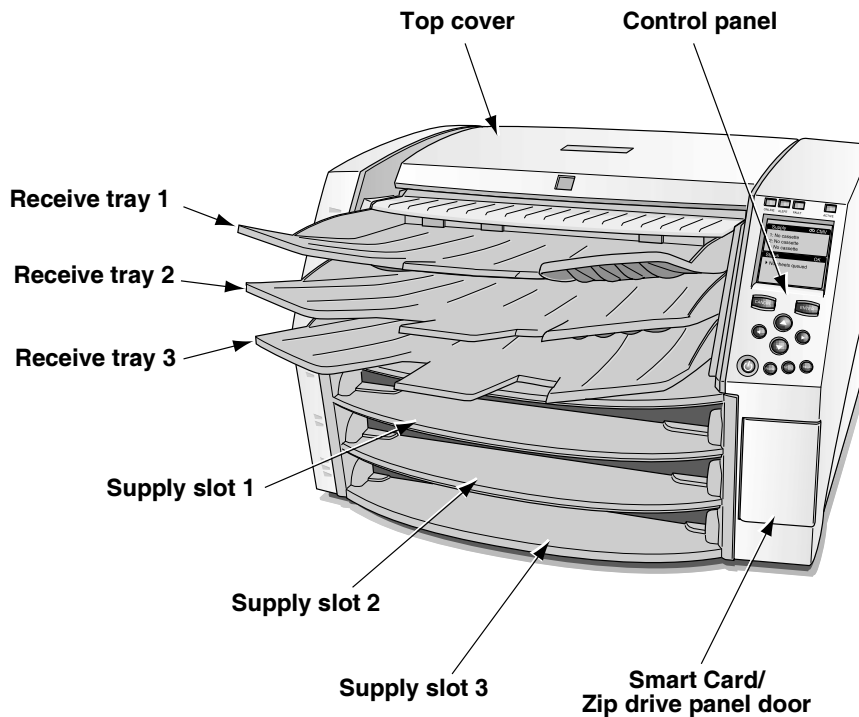

*Names and Locations of the Imager's Main Components—Front*

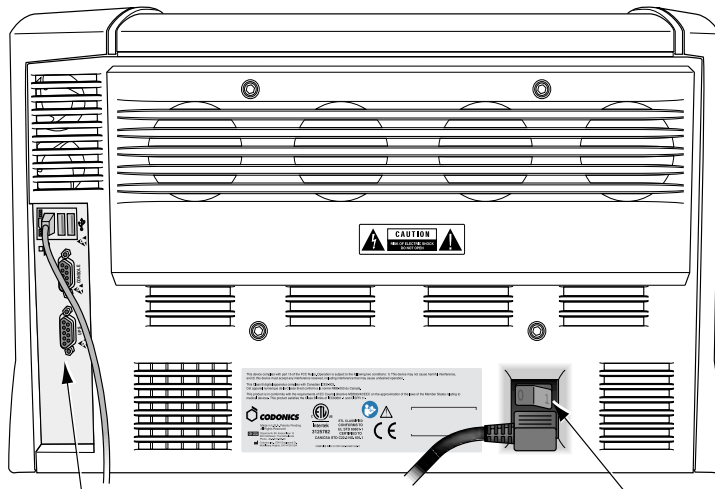

Connectors

Power rocker switch

***Names and Locations of the Imager's Main Components—Rear***

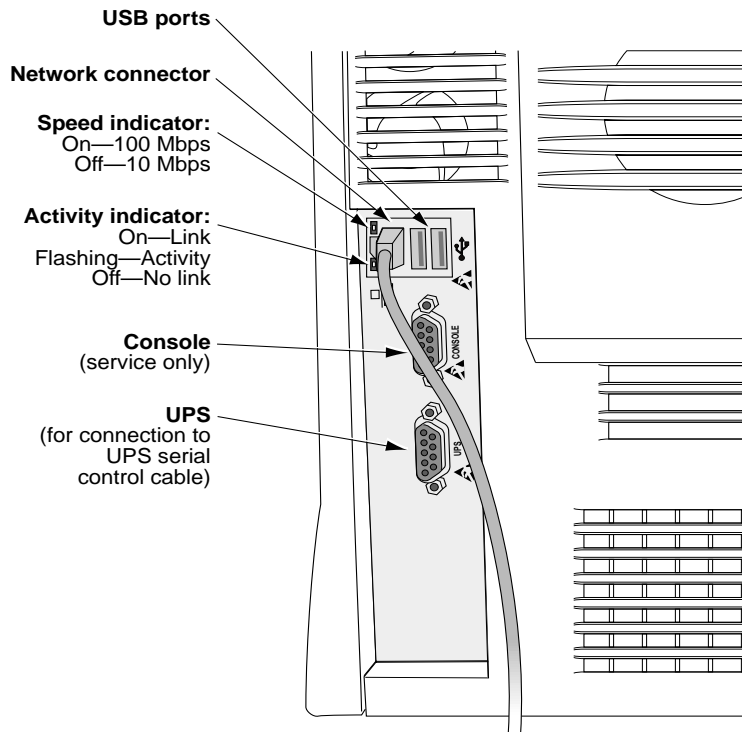

***Rear Connectors***

# Powering the Imager On and Off

## Powering On the Imager



To power on  
the imager

Press the  (power) key at the control panel.

The startup process takes 2 to 3 minutes. When the Status screen displays, the imager is ready to receive images.



**NOTE:** *The Horizon Imager Technical Manual includes information about how to obtain more detailed imager status information.*

## Observing the Imager's Operating Status in the Status Screen

The Status screen allows you to observe the imager status. The top portion of the screen—the Supply window—displays the status of the three supply cassettes and whether a color ribbon is installed. The bottom portion of the screen—the Status window—displays printing status messages and the imager's operational state.

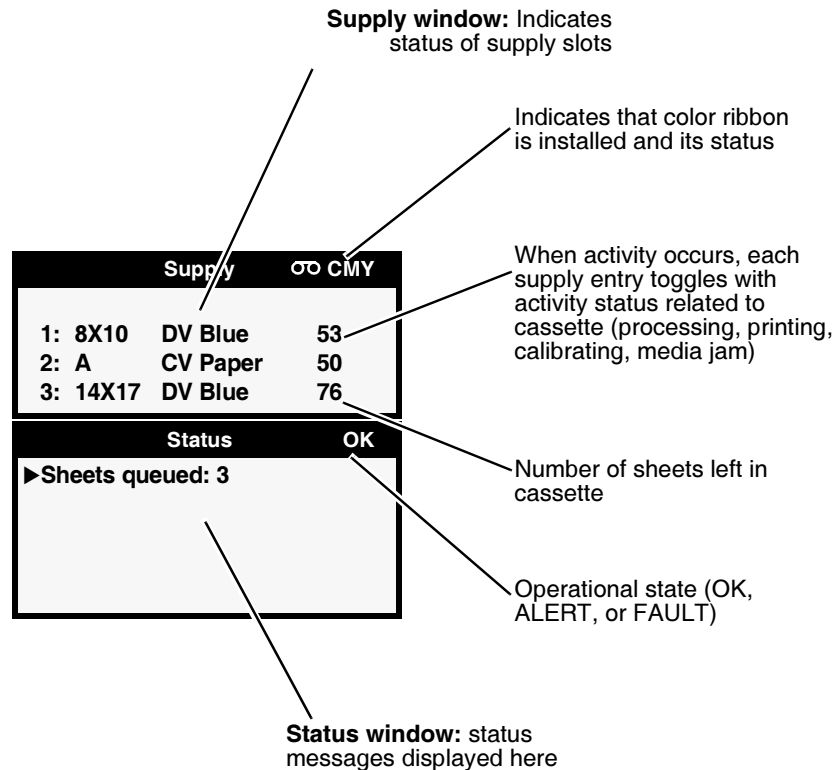

To get additional information about the currently selected status message, press the **HELP** key.



## Common Cassette Status Messages

The following table lists common cassette-related status messages.







**Table 2-1. Cassette Status Messages**

Message	Explanation
Calibrating	The imager is performing a calibration.  When performing a film calibration (when a <b>DirectVista</b> grayscale film cassette is first inserted, or initiated manually through the Main Menu), the “calibrating” message toggles with supply information.
Checking cassette	The imager is reading the supply cassette’s barcode, or waiting to read the barcode (for example, if the top cover is open, the barcode will not be read).
<i>Media size, type, and count</i>	Indicates the type, size, and sheet count of the media cassette inserted in the corresponding supply slot. For example, <b>14x17 DV Blue 53</b> , indicating the cassette currently has 53 sheets of 14 x 17-in. <b>DirectVista</b> blue film.
No cassette	No cassette is loaded in the supply slot.
Printing	The imager is printing from the indicated cassette.
Cleaning	The imager is cleaning the picking system.

## Color Ribbon Status

The following table lists the color ribbon status indications.

Table 2-2. Color Ribbon Status Indications

Indication	Explanation
	Blank; the imager does not support <b>ChromaVista</b> color media.
	Ribbon loaded. Ribbon type indicated (for example, <b>CMY</b> for cyan/magenta/yellow).
	Ribbon loaded but the ribbon is spent.
	Ribbon not loaded (and the imager does support ChromaVista color media).
	State of ribbon being determined.
	Ribbon loaded but in an error condition.

## Powering Off the Imager



To power off  
the imager

1. Press the  (power) key at the control panel.

The Power menu displays.

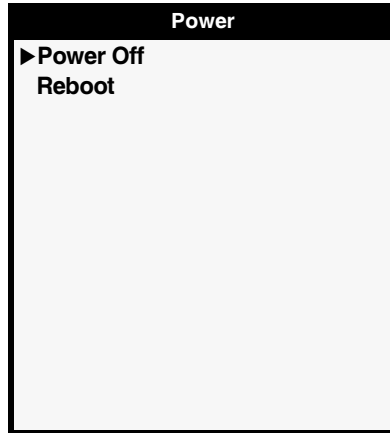

**NOTE:** To cancel the power off, press the  key again or the **CANCEL** key.

2. Select the **Power Off** option.

Shutdown messages are displayed. When the shutdown operation is complete, the imager powers off.



**NOTE:** Always use the  key at the control panel to power on/off the imager. The power rocker switch at the back of the imager should always be in the **1** (on) position, unless the imager is being serviced or moved.



**CAUTION** If the imager is powered off using the  key, unprinted queued jobs are saved and will finish printing once the imager is powered on again. However, if the imager is powered off using the rocker switch in the back or power is interrupted, queued jobs may be lost.

# Understanding the Control Panel

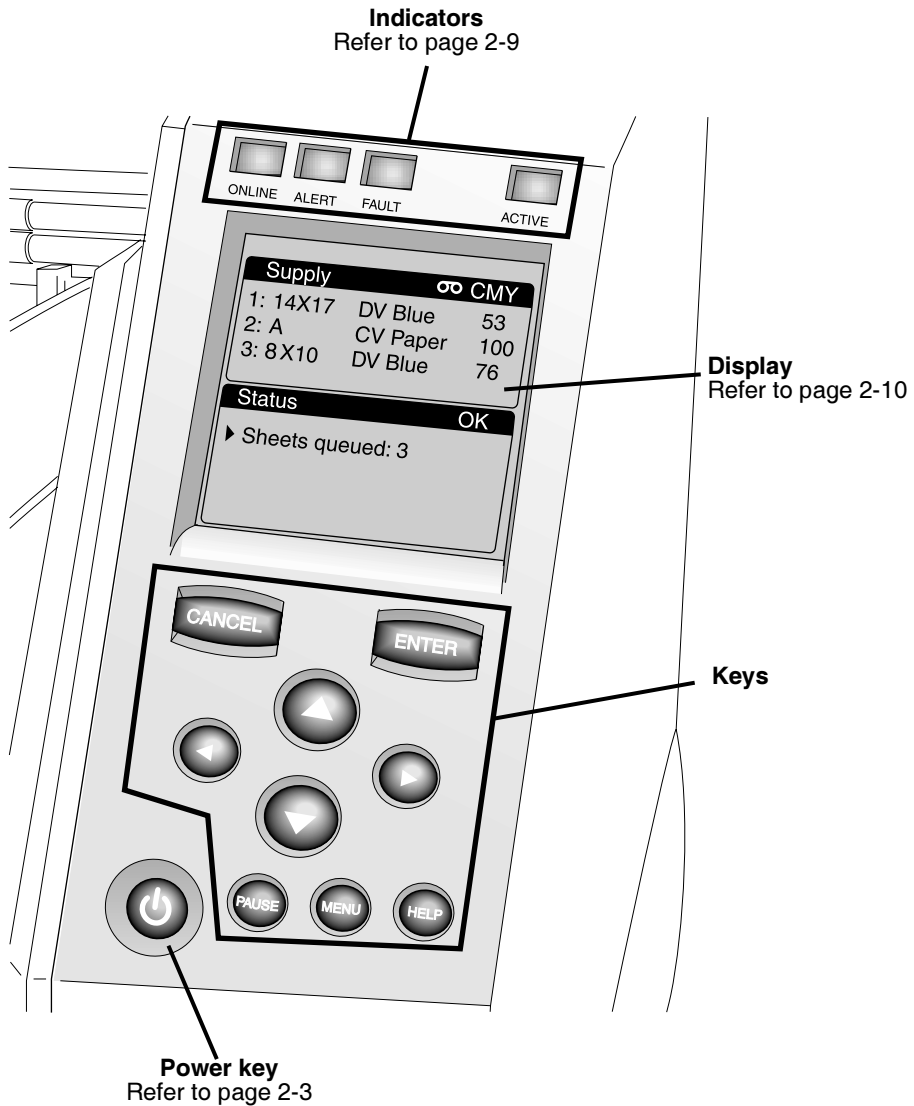

## Control Panel Indicators

The following table describes the control panel indicators.

**Table 2-3. Control Panel Indicators**

Indicator	Description
<b>ONLINE</b> (green)	<p>Indicates when imager is online (lit) or offline (off):</p> <ul style="list-style-type: none"><li>• When online, printing is enabled.</li><li>• When offline, printing is paused.</li></ul> <p>In both cases, the imager will continue to receive and process print jobs.</p>
<b>ALERT</b> (yellow)	<p>When lit, indicates a condition that requires operator attention, but printing can continue.</p> <p>An example of an alert condition is a queued job that requires a supply cassette that is currently not loaded or is empty, but other cassettes are not empty.</p>
<b>FAULT</b> (red)	<p>Indicates an imager fault condition that prevents the imager from printing any job and requires operator intervention. For example:</p> <ul style="list-style-type: none"><li>• A sheet is jammed</li><li>• No supply cassettes are loaded</li><li>• All supply cassettes are empty</li></ul>
<b>ACTIVE</b> (green)	<p>Has the following states:</p> <ul style="list-style-type: none"><li>• On: The imager is powered on but idle.</li><li>• Off: The imager is powered off.</li><li>• Flashing: The imager is actively receiving, processing, or printing jobs; or powering on, off, or rebooting. If jobs are paused, the <b>ACTIVE</b> indicator will not flash.</li></ul>

## **Alert and Fault Messages and the Fault Tone**

When the imager needs attention or an error occurs, the **ALERT** or **FAULT** indicator lights. Messages are displayed in the Status screen to help you respond to the condition.

If operator intervention is required, a Fault tone sounds. To stop the Fault tone, press any control panel key.



For more information about alert and fault messages and how to respond to them, refer to Chapter 9.

## **Control Panel Display**

### **Main Menu**

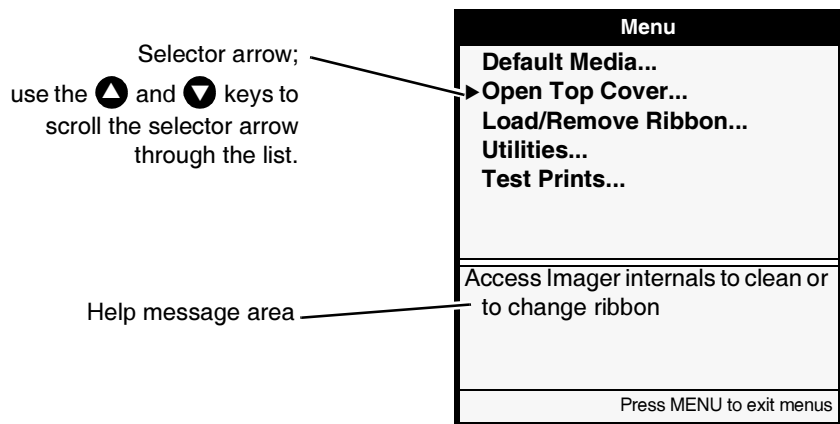
When the  key is pressed, the Main Menu displays. Use the Main Menu to perform basic and frequently used imager operations.



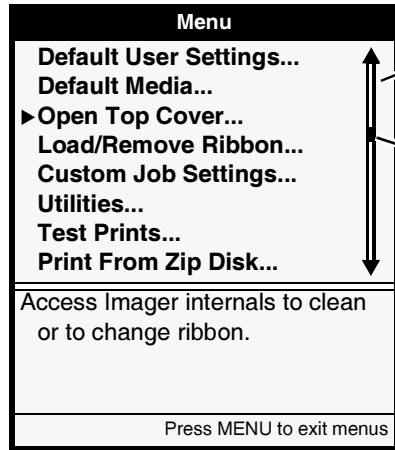

If you press the  key and, while holding it, press the  key, the Status screen shows additional administrative options in the menus. You use these additional options to perform system maintenance and setup tasks.



Scroll indicator displays when there are more menu items available than can be displayed at one time.

Black portion of scroll indicator indicates where the selected item is within the complete list.

Use the  and  keys to scroll the selector arrow through the list.



To exit the Menu screens

When finished, press the  key. The Status screen is displayed.





# 3

## Media Handling and Storage

### Overview

#### Supply Slots and Cassettes

Media used with the Horizon imager is prepackaged in factory-sealed, disposable cassettes.

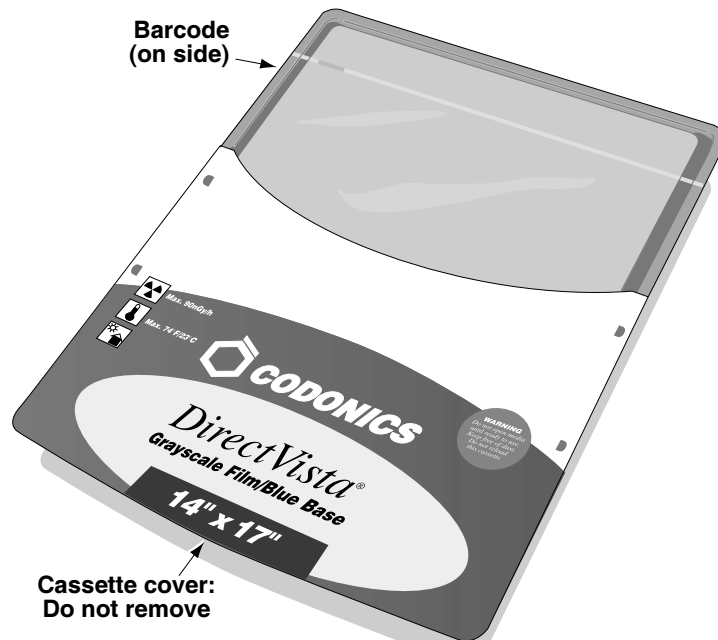

Each cassette contains a barcode that allows the imager to track how many sheets remain in the cassette (this count will be inaccurate if sheets have been manually added or removed, or the cassette has been moved to a different imager).

In addition to the barcode itself, the cassette's lot number and "Use by" date are printed on the barcode label.

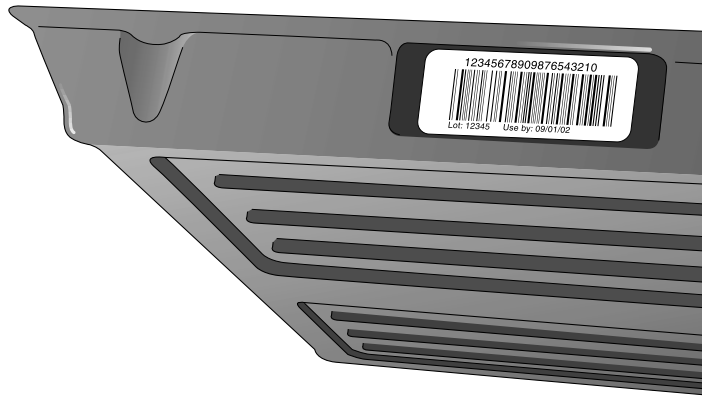

All cassettes can be loaded into any of the imager's three supply slots. By default, the printer ejects completed prints to the corresponding receive tray.



**CAUTION** Use only Codonics media. Do not use plain paper, office transparencies, or other unapproved media as damage, improper operation, or malfunction may result. For information about the approved Codonics media types and sizes, and how to order cassettes, refer to "Ordering Media" on page 3-10.



**CAUTION** Do not refill a cassette. Do not tamper with or remove the barcode label. The cassette's barcode information is essential for ensuring diagnostic image quality. Compromising the cassette in any way jeopardizes the quality and reliability of the imager.

### Viewing the Status of a Supply Slot

The Status screen shows the status of each supply slot, including media type, size, and number of sheets remaining.

Supply		CMY
1: 8X10	DV Blue	53
2: A	CV Paper	100
3: 14X17	DV Blue	76

Status	OK
▶ 3 sheets queued	

# Inserting or Changing Cassettes



To change a  
supply  
cassette

1. Press the **PAUSE** key, and wait until the **ONLINE** indicator turns off and the Status screen indicates that the imager is paused.

If a sheet is currently being printed, the sheet will complete printing before the imager enters the Paused state. While paused, the imager can still receive and process jobs.



**CAUTION** Do not remove or insert a cassette while a sheet is being printed, or you could affect the image quality of the printed sheet or cause a jam. Always pause the imager first.

2. Remove the cassette if one is currently in the supply slot you want to use—lift the cassette up slightly and slide it from the supply slot.
3. If inserting a new cassette, remove the clear wrapping from the cassette. Use the pull strip to tear the clear wrapping.

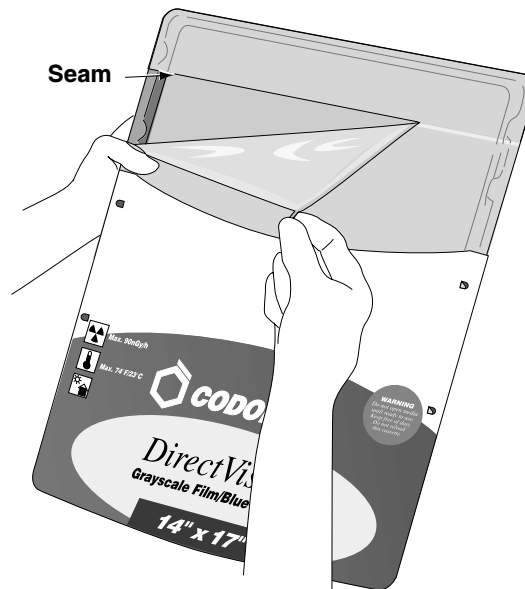



**CAUTION** Do not remove the printed cassette cover; it protects the media from dust and other contaminants. Always hold and store the cassette with the open side up to prevent the sheets from falling out.

4. Insert the new cassette into the supply slot, with the cassette label facing you and the barcode label to the left.



5. Slide the cassette into the supply slot until you feel the cassette settle into the retaining detent.
6. Press the **PAUSE** key to resume printing.

# Handling and Storing Media

For best results, refer to the storage and handling instructions that come with the media.

## **Break-Off Leaders (ChromaVista Only)**

**ChromaVista** color paper and film have break-off leaders at the top and bottom to allow edge-to-edge printing:



To remove the  
break-off  
leader

On a completed print, bend the leader at the perforation line fully one way, then fully the other way. The leader will break away from the sheet.

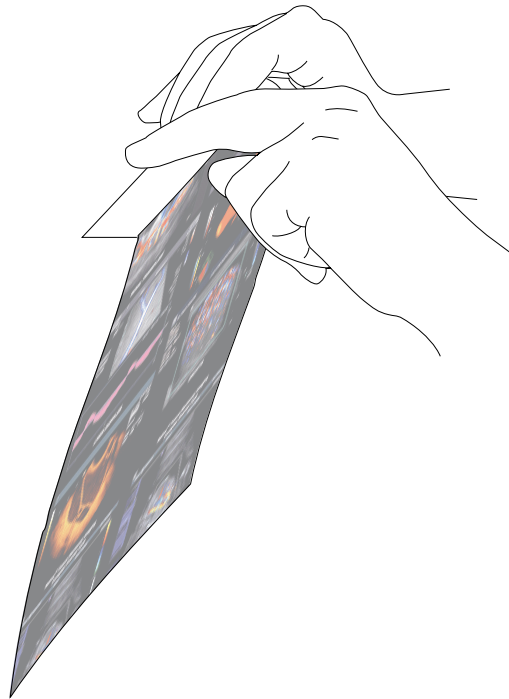

## Changing the Ribbon (ChromaVista)

When the ribbon on the ribbon spools has been consumed and needs to be changed:

- The imager enters the Alert state.
- A message indicating that a new ribbon needs to be loaded is displayed in the Status window.



To change the color ribbon

1. Press the **MENU** key.

The Main Menu displays.

2. Select the **Load/Remove Ribbon** menu option.

After selecting this option:

- The imager pauses, first completing the sheet if one is currently printing.
  - The ribbon supply spool inside the imager rises.
  - After up to a minute to allow the thermal print head to cool, the imager cover pops partially open.
3. Lift the cover all the way open, and locate the ribbon spools.



**WARNING** With the imager cover open, touch only those internal components that are colored green (except for the pick tires, refer to the figure on page xx). Remove rings, ties, jewelry, and other items, and tie back hair, so that they do not fall into or get caught in the imager.

4. Remove the old ribbon, as shown in the following figure.

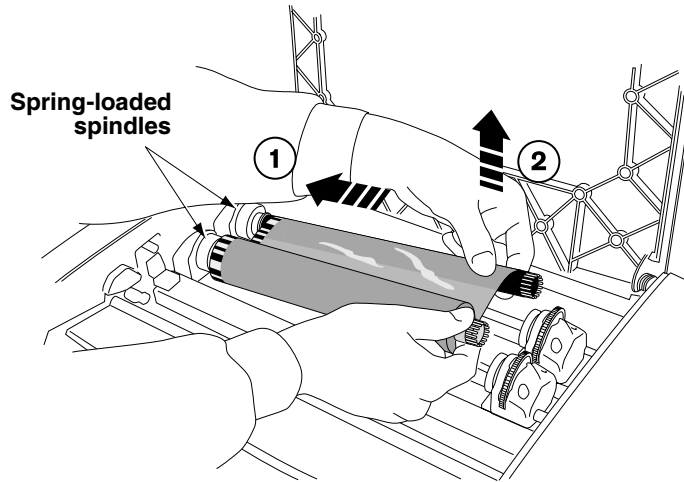

5. Load the new ribbon, as shown in the following figure.

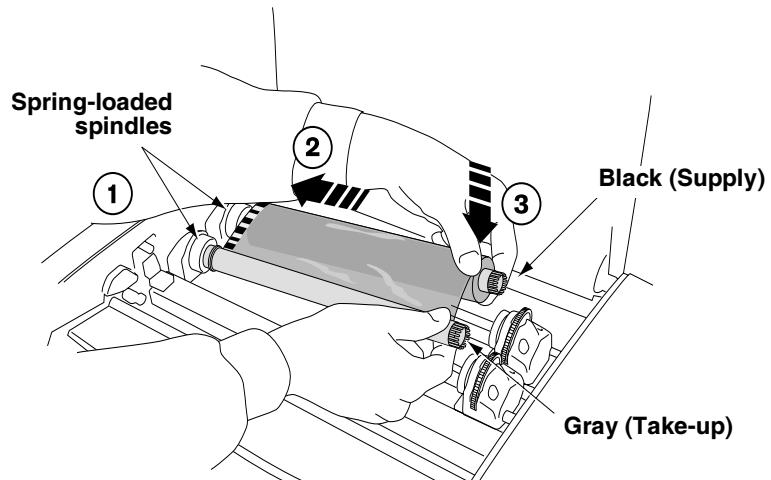



6. To take up any ribbon slack, rotate the top of the take-up spool's wheel (that is, the front wheel) towards the back of the imager, as shown in the following figure.

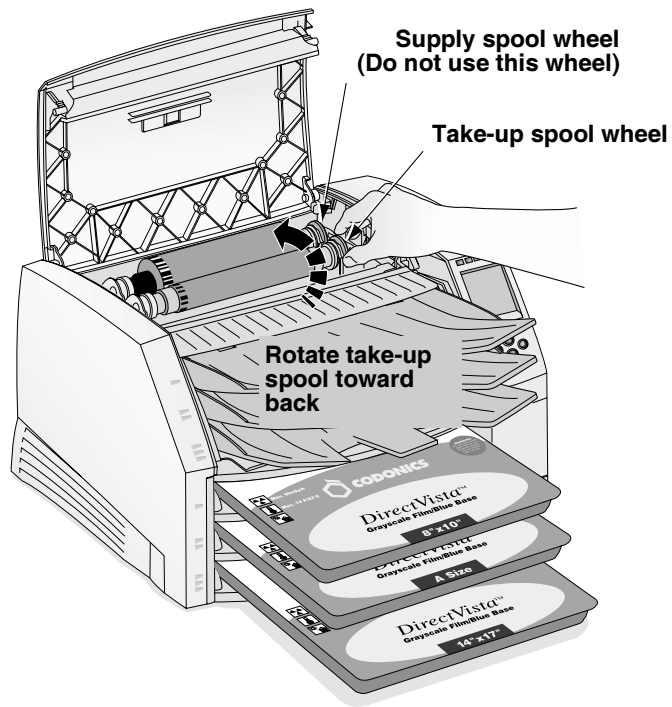

**NOTE:** Do not use the supply spool (rear) wheel to take up ribbon slack. This would cause spent ribbon to be reused.

7. When you are finished changing the ribbon, close the top cover.  
After several seconds, the imager will leave the paused state and resume printing.



**CAUTION** Used ribbon retains the negative of the color images that were printed using that ribbon. If you are required to ensure patient confidentiality and privacy, the ribbon should be destroyed.

# Ordering Media

The Horizon imager supports a variety of paper and film for both grayscale and color prints. Not all Horizon imager configurations support all media types and sizes. If your Horizon imager does not support the media type and/or size you want to use, contact your Codonics representative.

The following table shows the currently supported media size/type combinations:

Media Type	Size	Catalog Number
<b>DirectVista Paper/White Film</b>	A (8.5 x 11 in.)	A-DVP
	A4 (210 x 297 mm)	A4-DVP
	11 x 14 in. (28 x 35 cm)	1114-DVP
	14 x 17 in. (35 x 43 cm)	1417-DVP
<b>DirectVista Film Blue</b>	8 x 10 in.	810-DVB
	11 x 14 in.	1114-DVB
	14 x 17 in.	1417-DVB
<b>DirectVista Film Clear</b>	8 x 10 in.	810-DVC
	14 x 17 in.	1417-DVC
<b>ChromaVista Paper/WhiteFilm</b>	A	A-CVP
	A4	A4-CVP



*NOTE: Some of the media type/size combinations listed here may not currently be available.*

# 4

## Printing from DICOM Applications

The printing procedures covered in this chapter assume that the DICOM support option is installed in your Horizon imager and that you are sending print jobs from a DICOM application.



**NOTE:** *If you are running DICOM Lite on the imager and see connection errors at the console or workstation from which you are sending print jobs, you may require full DICOM. Contact Codonics technical support for assistance (refer to “Contacting Technical Support” on page 9-20).*

## Introduction to DICOM

DICOM (Digital Imaging and COmmunications in Medicine) is the industry standard for transferring images and other medical information. The Horizon imager is DICOM Print Service Class-compliant.

For more information about DICOM, visit the official web site—[medical.nema.org](http://medical.nema.org). Additional information is available at the web site of the Radiological Society of North America, Inc. ([www.rsna.org](http://www.rsna.org)).

## **DICOM Conformance Statement**

The Horizon imager conformance statement is available on the Codonics web site ([www.codonics.com](http://www.codonics.com)). It can also be mailed or faxed to you on request.

## **Configuring the DICOM Application**

Your key operator or DICOM application vendor must configure the DICOM application running on each imaging device printing to the Horizon imager. This application is the *Print Service Class User (SCU)*. The imager is the *Print Service Class Provider*.

Two pieces of information must be entered into the SCU: the *Called AE Title*, and the imager's TCP port number. This information does not usually need to be configured at the Horizon imager.

The port number is 104.

Common AE Titles are listed in the following table, which also describes how they are used.

<b>Called AE Title That Can Be Used</b>	<b>Description</b>
Print_SCP	For standard print jobs.
mcmBracket and gcsBracket	For printing bracketing sheets. For more information, refer to the <i>Horizon Imager User's Manual</i> .
SpecialSlide	For printing 35-mm slides. For more information, refer to the <i>Horizon Imager Technical Manual</i> .
<i>The name of a Job Settings file</i>	For printing using Job Settings files to specify print job parameters. For a list of Job Settings files provided with the imager, refer to Appendix B.

Additional instructions about configuring DICOM are included in the *Horizon Imager Technical Manual*.

## ***Sending a DICOM Print Job***

How you select a Horizon imager as a destination, then send a print job to it, is unique to your specific DICOM user application. For details, refer to your key operator, DICOM user application vendor, or the accompanying DICOM application documentation.

### ***Specifying the Media Type and Size***

Typically, you will set the media type and size to use for a given print job from within the SCU DICOM application. However, if your application does not support the correct size and type of media, you have two options:

- Use a System Job Settings file (listed in Appendix B) as the Called AE Title. This will force the print job to the correct media size and type. This is useful when only the media needs to be specified via AE title.
- Use a Custom Job Settings file that specifies the desired media type/size. Custom Job Settings are most useful when several print Job Settings must be controlled at the printer rather than at the DICOM application.

## ***Using Job Settings Files with DICOM***

Occasionally it is possible that there is a setting supported by the Horizon imager that cannot be specified in your DICOM application. Using the imager's *Job Settings* feature, you can work around this limitation.

The Horizon imager supports multiple Job Settings files, each of which can define unique sets of sheet and image settings. A Job Settings file can specify values for some or all sheet and image settings. Settings include the media size and type, border color, Dmax or Dmin, etc.

## **Categories of Job Settings**

There are two categories of Job Settings:

- **System Job Settings.** These Job Settings files come preconfigured in the Horizon imager. They include a Job Setting for each media type and size combination, for the three receive trays, and for the three job priorities. For a complete list of the system Job Settings files, refer to Appendix B.
- **Custom Job Settings.** These Job Settings are created at the user site. They can be entered at the control panel, or by sending a text file to the imager via FTP or LPR protocols. The procedures for creating custom Job Settings files are described in the *Horizon Imager Technical Manual*.

## **Specifying a Job Settings File from a DICOM User Application**

Since the Horizon imager supports multiple Job Settings files, and since those files are controlled by entering special Called AE Titles, it is common to have several printer configurations set up in a DICOM user application all pointing to a single Horizon imager. A typical setup strategy creates separate profiles by media size and type.

For example, the System Job Settings file that specifies **DirectVista** 8 x 10 blue film is **8x10-dvfb**. To specify **DirectVista** 8 x 10 blue film for a print job, the DICOM user application would use **8x10-dvfb** as the Called AE Title when starting a Print Service Class session with the Horizon imager. The DICOM user application may also print color. Therefore, there will be a second printer setup on the SCU with the AE title **a-cvp**.

The Horizon imager also supports IP aliasing for systems that do not support configuring more than one AE title per IP address. For more information about how multiple IP addresses and DICOM printing to the Horizon imager can be implemented, refer to the *Horizon Imager Technical Manual*.

## **Hierarchy of Settings Used by the Horizon Imager**

For DICOM print jobs, the Horizon imager uses the following sequence to determine which sheet and image settings to use:

1. Specified Job Settings file (System or Custom).
2. For any sheet or image settings not specified in the Job Settings file, look in the DICOM application settings.
3. For any sheet or image settings not specified in the Job Settings file or DICOM application, uses the imager's Default User Settings.

For more information on the hierarchy of settings, refer to the Horizon imager's DICOM Conformance Statement, and to the *Horizon Imager Technical Manual*.





# 5

## **Printing from Windows via PostScript**

The printing procedures covered in this chapter assume that:

- The PostScript support option is installed in your Horizon imager.
- The Horizon imager has been configured as a Windows desktop printer on your workstation using the Horizon PostScript print driver.
- You are sending print jobs from a Windows (Windows 98, Me, NT 4.0, 2000, or XP) application.
- You are familiar, in general, with how to print from Windows applications to a desktop printer.

Complete instructions for adding a Horizon imager as a desktop printer are provided in the Horizon PostScript Driver Technical Briefs, available in PDF format on the Horizon PostScript Drivers CD-ROM.

For how to send PostScript files from a Macintosh, refer to the *Horizon Imager User's Manual*.

For how to send PostScript files from UNIX or Linux, refer to the *Horizon Imager Technical Manual*.

## **Introduction to PostScript**

PostScript printing technology was developed to provide consistent, predictable printing from every major computer platform to any printing device that supports it.

There have been three PostScript technologies released since its inception—levels 1, 2, and, the most recent version, 3. The Horizon imager supports all three levels.

## **Printing from Windows Applications**

For detailed descriptions about print job, sheet, and image parameters, refer to the *Horizon Imager Technical Manual*.

### **Notes About Changing PostScript Parameters**

- To avoid unpredictable results, change the defaults for only those Horizon imager parameters listed in the *Technical Manual*.
- Settings changed via the Print dialog boxes will take precedence over settings made at the imager.

## Changing Horizon PostScript Parameters—Windows 2000 and XP



**NOTE:** This procedure assumes that the PostScript driver for the Horizon imager has already been installed on the workstation. For more information, refer to the “Windows 2000 Driver Installation—Horizon” or “Windows XP Driver Installation—Horizon” Technical Brief. Refer to the Horizon User’s Manual for information on other versions of Windows.



To change the PostScript parameters in Windows 2000 and XP

1. Initiate the print job from the Windows application.

The Print dialog box displays.

2. Make sure that the Horizon imager is the selected printer.
3. Click the **Properties** button.

The Document Properties dialog box displays.

4. Click the **Advanced** button.

The Advanced Options dialog box displays.



5. Specify a Horizon media size and type combination from the **Paper Size** drop-down list. The Horizon media choices begin with “HZ.”
6. To specify any of the other Horizon PostScript parameter settings, scroll to the **Printer Features** list of parameters.
7. When you are done changing settings, click **OK** to save your changes.

The settings you have saved will be in effect for the current session of the application from which you are printing. If you open a new session of the application or print from a different application, the parameters revert to their default settings.

# 6

## Default Print Job Settings

Every print job has parameters associated with it that control how the job is to be processed (for example, media size and type, scaling, gamma, contrast, and so on).

The Horizon imager has a complete set of *default settings* for every media type/size, sheet, and image parameter of a print job. The default settings can be viewed and changed through the control panel. Default settings are applied when no other source, such as the application or PostScript driver, supplies settings.



**CAUTION** Use caution when changing the imager default settings. Changes could affect prints made by other users. Use Job Settings to avoid affecting other users.

Most DICOM applications support some, if not all, image and sheet settings. Commonly-supported settings include Dmin, Dmax, and trim lines.

Since any setting that appears in the control panel also appears in the PostScript driver, it is usually more convenient to change settings in the driver rather than in the control panel of the Horizon Imager.

Refer to the *Horizon Imager Technical Manual* for a summary of the print job parameters that can be changed.

# Changing the Default Settings

## Changing the Default Media Type and Size

One default media is specified for grayscale images, and one for color images.

In practice, the PostScript driver or DICOM application will override the Default Media setting. Default Media is available for the small number of installations for which this is not the case.

When the imager receives a grayscale image, it prints the image to the default grayscale media type and size, unless otherwise specified. Likewise, when the imager receives a color image, it prints the image to the default color media type and size.



To access the  
Default Media  
settings

1. Press the **MENU** key.
2. Use the **▲** and **▼** keys to select the **Default Media** option, then press the **ENTER** key.
3. Select the desired image type—**Grayscale** or **Color**. A settings menu option is displayed for each available media type supported by your imager.





In addition to the settings options, the Default Media menu also contains an option to reset the settings.

## Changing the Default User Settings

Default User Settings are located in the Administrative-level Main Menu options.



To access the  
Default User  
Settings

1. Press the  key and, while holding it, press the  key.
2. Use the  and  keys to select the **Default User Settings** option, then press the  key. A settings menu option is displayed for each available media type supported by your imager.

In addition to the settings options, the Default User Settings menu also contains an option to reset the settings.



**CAUTION** If the imager's settings were changed from the factory defaults **prior** to being shipped (for example, to accommodate a special OEM configuration), resetting to the factory defaults will not restore the "as shipped" settings. Instead, they will be reset to the standard factory default values.



**CAUTION** Resetting to the factory defaults will affect prints made by other users. Use caution when changing default settings. Typically, it is better to specify sheet and image parameter settings from the DICOM application or a PostScript printer's settings, or use a Job Settings file that contains the values you need. For information about Job Settings files, refer to the *Horizon Imager Technical Manual*.





## 7

# Preventive Maintenance

## Recommended Maintenance Schedule

The major cause of degraded imager performance and image output quality is dirt and dust. Perform the following preventive maintenance periodically.

**Table 7-1. Recommended Maintenance Schedule**

Maintenance	Schedule	Procedure on
Clean the thermal print head and nosepiece	<ul style="list-style-type: none"> <li>• Every 1000 sheets.</li> <li>• If you notice image quality problems.</li> <li>• If there is visible accumulation of debris.</li> </ul>	page 7-3
Clean the platen roller and donor guide bar	<ul style="list-style-type: none"> <li>• Every 1000 sheets.</li> <li>• If you notice image quality problems.</li> <li>• If there is visible accumulation of debris.</li> <li>• If the imager has trouble printing.</li> </ul>	page 7-3
Clean the pick tires	<ul style="list-style-type: none"> <li>• Every 1000 sheets, or more often in dirty conditions.</li> <li>• If the imager has trouble picking sheets from a cassette.</li> <li>• If the imager has trouble printing.</li> </ul>	page 7-7

**Table 7-1. Recommended Maintenance Schedule (cont.)**

<b>Maintenance</b>	<b>Schedule</b>	<b>Procedure on</b>
Clean the barcode reader window	Every 12 months.	<i>Horizon User's Manual</i>
Clean the cassette area, sheet exit area, receive trays, basement, and imager cabinet with a platen roller wipe (refer to "Horizon Cleaning Kits" below)	Every 2000 sheets to eliminate dust buildup and prevent dirt from getting inside the imager.	<i>Horizon User's Manual</i>
Film calibration	This calibration is done automatically whenever a new cassette is inserted for the first time. You can also run this calibration manually at any time (for example, if it has been more than three months since the cassette was calibrated).	page 8-1

## **Horizon Cleaning Kits**

The following cleaning kit is available to help you properly maintain the Horizon imager:

- The Horizon Platen and Print Head Cleaning Kit (catalog no. SP-00118) includes the special thermal print head and platen roller wipes that you will need to clean the thermal print head, platen, donor guide, and pick tires.
- The Horizon Barcode Reader Cleaning Kit (catalog no. SP-00130) includes the cotton swabs that you will need to clean the barcode reader window.

To order additional cleaning kits, contact Codonics at:

**Phone:** +1.440.243.1198  
**Toll Free:** 800.444.1198 (USA Only)  
**Fax:** +1.440.243.1334  
**Web:** [www.codonics.com](http://www.codonics.com)

# Cleaning the Thermal Print Head and Platen Roller

1. Press the imager's **MENU** key.

The Main Menu displays.

2. Select the **Open Top Cover** menu option.

The imager pauses and, after up to a minute to allow internal components to cool, the top cover pops partially open.

3. Open the top cover all the way.



**WARNING** With the imager cover open, touch only those internal components that are colored green (except for the pick tires, refer to the figure on page xx). Remove rings, ties, jewelry, and other items, and tie back hair, so that they do not fall into or get caught in the imager.

If a color ribbon is loaded, go to step 4. Otherwise, go to step 7.

4. Remove the color ribbon, as shown in the following figure.

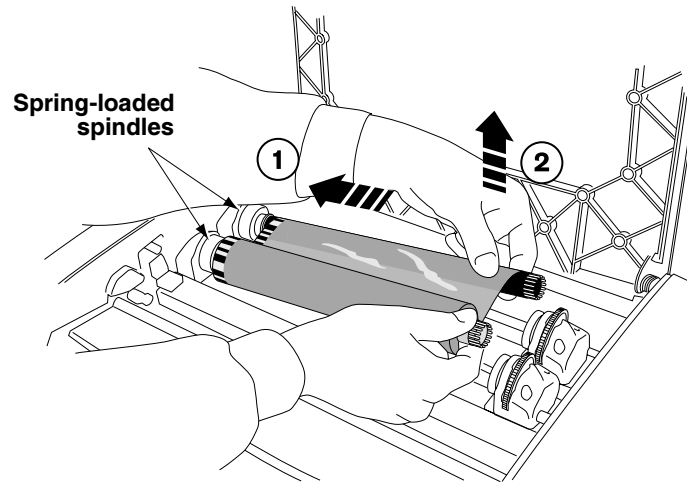

**NOTE:** Care should be taken to protect the ribbon from dust and dirt when not loaded in the imager. Avoid resting the ribbon on a table; static charge will attract dust from the table top.

5. From the **Open Top Cover** menu, select the **Move Ribbon Carriage** menu option.
6. Press the **▼** key to move the ribbon carriage down and out of the way.
7. Locate the print bead and nosepiece, shown in the following figure.

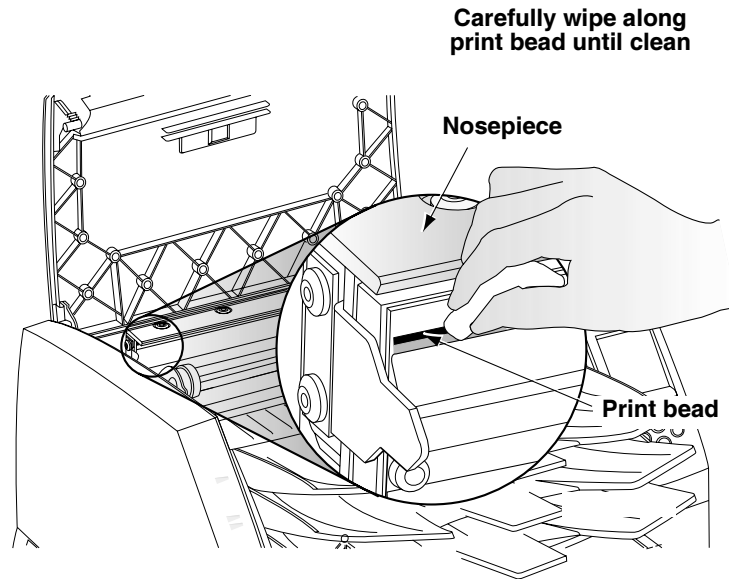

**CAUTION** To avoid thermal print head damage:

- Use only the print head cleaning wipe when cleaning.
- Do not touch the glass surface of the thermal print head with fingers; wearing gloves is advised.



**WARNING** The thermal print head may be hot.

8. Using the print head cleaning wipe provided with the imager's cleaning kit, carefully wipe back and forth along the entire length of the print bead line with moderate pressure. The cleaning wipe may become discolored. Repeat the back and forth motion until the print bead is completely clean.
9. Clean any dust or other contaminants from the nosepiece.
10. Looking in from the side of the imager, locate the orange or white platen roller and donor guide bar, shown in the following figure.

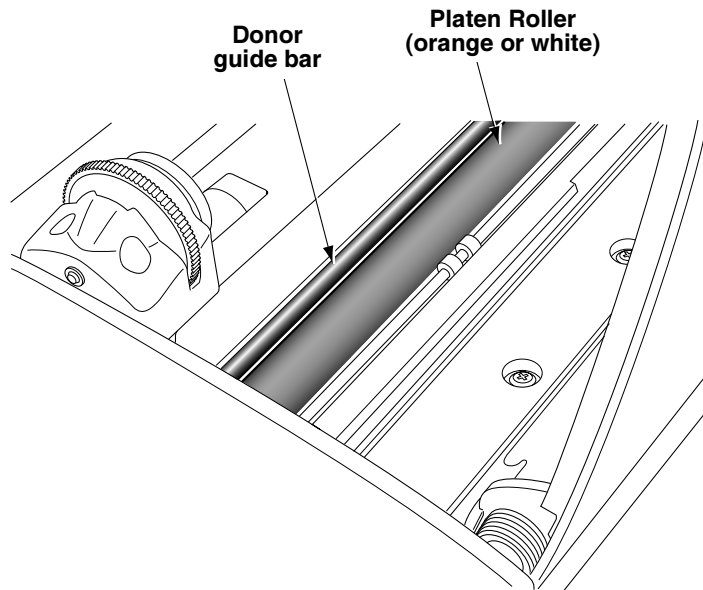

11. If the **Move Ribbon Carriage** menu is displayed, press the **◀** key to return to the **Open Top Cover** menu.
12. From the **Open Top Cover** menu, select the **Rotate Platen** menu option.  
The **Rotate Platen** menu is displayed.
13. Using the platen roller cleaning wipe provided with the imager's cleaning kit, rub the wipe in one direction only along the entire length of the platen roller from end to end until all visible contaminants are gone. Do not rub back and forth.

Press the ▲ or ▼ key to incrementally rotate the platen roller so that you can clean its entire surface.



**CAUTION** Use only the platen roller cleaning wipe when cleaning the platen roller. Damage to the platen roller may occur if the print head cleaning wipe is used.

14. Clean any dust or other contaminants from the donor guide bar using the platen roller or print head cleaning wipe provided with the imager's cleaning kit.
15. Wait for the thermal print head and platen roller to dry thoroughly.



**CAUTION** The thermal print head must be completely dry before attempting to use the imager. Allowing the head to heat up again while still wet will cause damage.

If you need to reload the color ribbon, go to step 16. Otherwise go to step 18.

16. From the **Open Top Cover** menu, select the **Move Ribbon Carriage** menu option. Press the ▲ key to move the ribbon carriage up so you can reload the color ribbon.
17. Reload the color ribbon, as shown in the following figure.

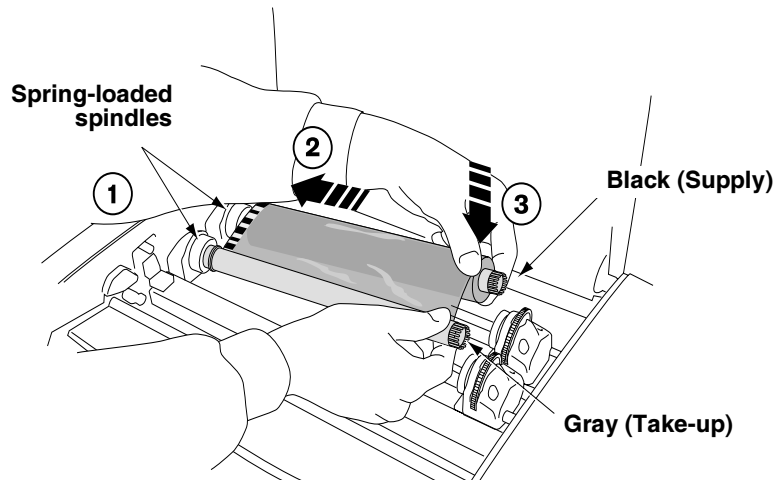

18. Close the top cover.

## Cleaning the Pick Tires

Some Horizon users may prefer to use the Horizon Cleaning Cassette to clean the pick tires, rather than using the platen roller cleaning wipe. The Horizon Cleaning Cassette, part number SP-00279, can be ordered by contacting your Codonics representative.

1. Press the imager's **PAUSE** key, and wait until the imager enters the Paused state.
2. Remove the receive trays, as shown in the following figure.

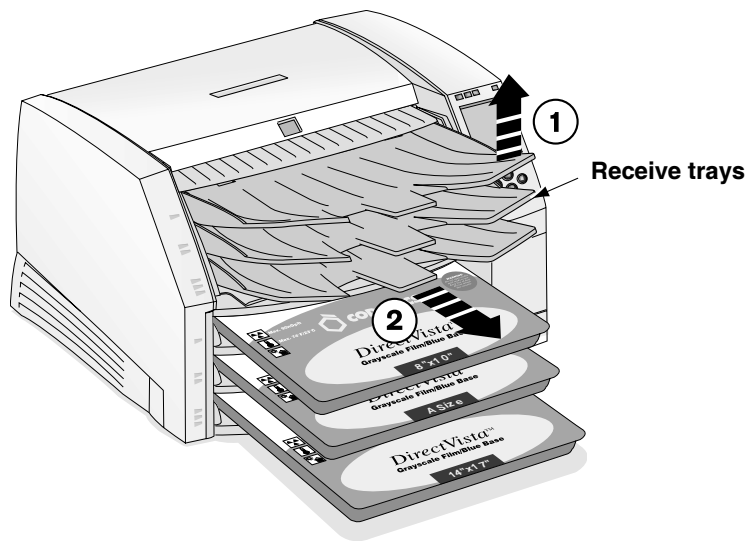

**WARNING** With the receive trays removed, touch only those internal components that are colored green (except for the pick tires, refer to the figure on page xx). Remove rings, ties, jewelry, and other items, and tie back hair, so that they do not fall into or get caught in the imager.

3. Place the receive trays on a flat surface, as shown in the following figure.

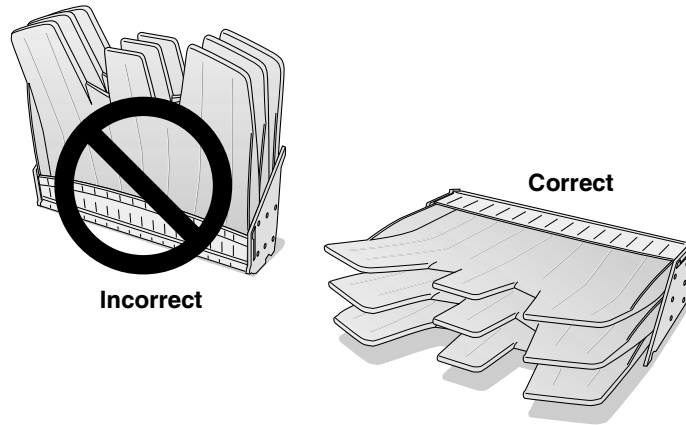

4. Remove any cassettes from the supply slots.
5. Locate the pick tires.

There are three pickers, one for each supply slot. The topmost picker is shown in the following figure.

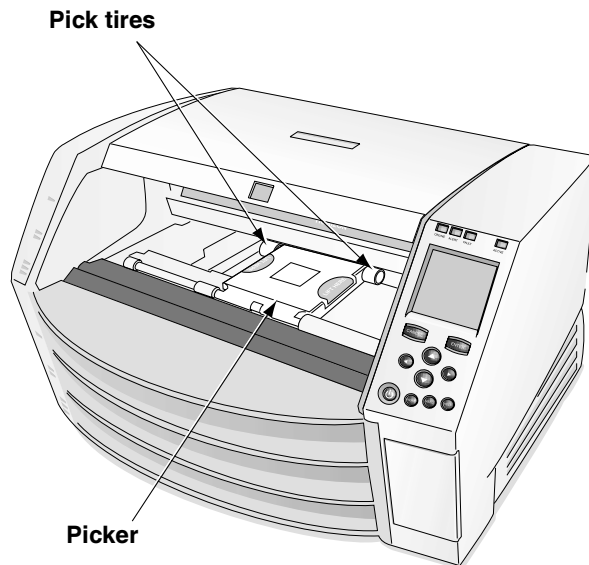



- Using the platen roller cleaning wipe provided with the imager's cleaning kit, wipe around each pick tire with the cleaning wipe. The cleaning wipe may become discolored.



**CAUTION** Do not touch the pick tires with fingers; body oils from your fingers are hard to remove and could eventually damage the tires.



**CAUTION** Use only the platen roller cleaning wipe when cleaning the pick tires. The tires could be damaged if you use the print head cleaning wipe.

- Wait for the pick tires to dry thoroughly.
- Replace the receive trays and any media cassettes that were removed.



# 8

## Film Calibration

Film calibration is the process of characterizing a given combination of imager and **DirectVista** grayscale film to allow the imager to compensate for imager-to-imager variation and supply cassette-to-cassette variation.

When a **DirectVista** grayscale film cassette is loaded into the imager for the first time, the imager will print a test sheet and read that test sheet with the built-in densitometer, then recalibrate based on the results.

You can also perform a film calibration manually.



To perform a  
film  
calibration

1. Press the **MENU** key.

The Main Menu displays.

2. Select the following menu options:

**Utilities**  
**Film Calibrate**

The Film Calibration menu displays, allowing you to choose the supply slot (referred to as Cassette 1, 2, or 3) in which the **DirectVista** grayscale film cassette is loaded.

3. Select the appropriate supply slot, then press the **ENTER** key.

The imager prints a test sheet, recalibrating that cassette based on the result.



**NOTE:** If the selected supply slot does not have a **DirectVista** grayscale film cassette loaded, the calibration will not run.



# 9

## **Troubleshooting**

### **Sources of Status Information**

#### **Control Panel**

The control panel has **ALERT** and **FAULT** indicators, which light when the imager needs attention.

#### **Error Log**

The imager logs error messages to a file.

1. Press the **MENU** key.

The Main Menu displays.

2. Select the following menu options:





Utilities  
Error Log

#### **Online Help for Displayed Messages**

You can display help text for a message displayed in the Status window by moving the selector arrow to the message, then pressing the **HELP** key.

# Troubleshooting Tables

**Table 9-1. Startup and Print Job Troubleshooting**

Problem	Possible Causes	Solutions
Imager does not power up when pressing the  (power) key at the control panel.	Imager is not turned on.	Push the power rocker switch at the back of the imager to the <b>1</b> (on) position, then retry pressing the  key at the control panel (refer to “Powering On the Imager—First Time” on page 1-8).
	Power cord is not properly connected.	Reset power cord on back of imager.
	No power at the outlet.	Try plugging another device into the outlet to check whether there is any power. If there isn’t power to the outlet, then check to see why.
	Internal fuse or power supply is bad.	The internal power supply contains an integrated fuse which is <b>not</b> user serviceable. Contact technical support.
Control panel display shows an error during startup.	Hardware component failed to initialize, component failure.	Cycle power by pushing the rocker switch at the back of the imager to the <b>0</b> (off) position. Wait 10 seconds. Refer to “Powering On the Imager—First Time” on page 1-8. If this does not clear the condition, contact technical support, making a note of the error message.
Imager does not respond to pressing any control panel keys.	Imager software has crashed.	Press and hold down the  key at the control panel to force a shutdown. Wait for the imager to power down, then press the  key again to restart.
		If this does not clear the condition, then cycle power. Refer to “Powering On the Imager—First Time” on page 1-8).
		If this still does not clear the condition, contact Codonics technical support.

**Table 9-1. Startup and Print Job Troubleshooting (cont.)**

Problem	Possible Causes	Solutions
<p>Print jobs have been sent but the <b>ACTIVE</b> light never flashes.</p>	<p>Internal problem with imager or with network connection.</p> <p>Trying to use an unsupported feature (for example, unsupported media, or the source—DICOM or PostScript—is not supported on your imager).</p> <p>A temporary feature key has expired.</p>	<p>Check that network cable is properly connected.</p> <p>Check that the Horizon imager's network settings are correct.</p> <p>Check that the Horizon imager's IP address is set correctly at the host sending the print job.</p> <p>Check that you are using only features that were purchased for and enabled on the imager.</p> <p>Check the error log using the Error Log function to see whether a required feature is not enabled. Contact your Codonics representative to purchase a permanent corresponding feature key.</p>
<p>Images transfer but no sheet is printed.</p>	<p>Correct media not loaded.</p> <p>A temporary feature key has expired.</p> <p>Trying to use an unsupported feature.</p>	<p>Look for message at the control panel status window, and load that requested media type.</p> <p>Check the error log using the Error Log function to see whether a required feature is not enabled. Contact your Codonics representative to purchase a corresponding permanent feature key.</p> <p>Check that you are using only features that were purchased for and enabled on the imager.</p>
<p>Image transfers but the image's cell on the printed sheet is empty. Instead, the cell contains the message "image processing failed."</p>	<p>Unknown or corrupt image file format.</p>	<p>Make sure images being sent to the imager are one of the supported formats.</p> <p>Make sure the sending application is not sending corrupt or incomplete images.</p> <p>Reinstall imager software.</p>

**Table 9-1. Startup and Print Job Troubleshooting (cont.)**

<b>Problem</b>	<b>Possible Causes</b>	<b>Solutions</b>
Sheet and/or image settings on printed sheets do not reflect what is set through the control panel.	Settings entered through the DICOM application interface a Job Setting are overriding the imager's Default User Settings.	To use the Default User Settings specified at the control panel, select a Horizon imager Called AE Title that does not specify any Job Settings parameters (for example, Print_SCP). Also, do not specify any custom settings through the DICOM application interface or PostScript printer settings. All settings will then defer to the imager's Default User Settings.
Status screen indicates "Head cooling, please wait ..." for extended period of time (greater than one minute), or this message displays often.	Improper ventilation.	Allow at least 10 cm (4 in.) at back and sides of imager.  Move imager to a cooler location.

**Table 9-2. Sheet Jam Troubleshooting**

<b>Problem</b>	<b>Possible Causes</b>	<b>Solutions</b>
Sheet jams or misfeeds.	The imager is being operated in an area of high or low humidity that is outside of the specified range for the imager. This can cause the media to curl.	Check the media for curling or other distortion. If there is distortion, replace the media. Try to control temperature and humidity in the area where the imager is located, or move the imager to a more suitable location.
	Sheet is still jammed in the imager.	If a sheet is still jammed in the imager, remove it (refer to "Clearing a Sheet Jam" on page 9-9).
	Dirty pick tires or platen roller.	Clean the platen roller (refer to "Cleaning the Thermal Print Head and Platen Roller" on page 7-3) and the pick tires (refer to "Cleaning the Pick Tires" on page 7-7).
	Sheets in the cassettes are blocked or stuck together due to heat, humidity, or improper storage.	To help prevent sheets from sticking together, store cassettes upright (the way they come packed in their shipping boxes), not lying flat.
	Receive tray is full.	Remove sheets from the receive tray.



**Table 9-3. Image Quality Troubleshooting**

<b>Problem</b>	<b>Possible Causes</b>	<b>Solutions</b>
Scratches (physical abrasions) on the sheet.	There is dirt on the thermal print head, or a burr or abrasion on a component in the media path.	Clean the thermal print head (refer to “Cleaning the Thermal Print Head and Platen Roller” on page 7-3).  Perform general cleaning procedures (refer to the <i>Horizon User’s Manual</i> ).
Spots or irregular streaks on the sheet.	Dust on the sheet.	Clean the thermal print head and platen roller (refer to “Cleaning the Thermal Print Head and Platen Roller” on page 7-3).  Perform general cleaning procedures (refer to the <i>Horizon User’s Manual</i> ).
Clear, hard-edged vertical white streak on all sheets.	Blown element on the thermal print head or bad cable.	Need new thermal print head or cable. Contact technical support.
Vertical streaking across the entire sheet.	Thermal print head needs to be calibrated.	Calibrate the thermal print head (refer to the <i>Horizon Technical Manual</i> ).
Dark spot that repeats every few inches on the sheet.	Dust on the platen roller.	Clean the platen roller (refer to “Cleaning the Thermal Print Head and Platen Roller” on page 7-3).
Multi-colored jagged streaks on colored sheet.	The ribbon may be wrinkled on the spool, or the ribbon is damaged.	Install a new ribbon [refer to “Changing the Ribbon (ChromaVista)” on page 3-7] and make another print.

**Table 9-4. Media Cassette and Ribbon Troubleshooting**

<b>Problem</b>	<b>Possible Causes</b>	<b>Solutions</b>
Printed sheets are falling from the imager.	Receive tray is full.	Remove the sheets from the receive tray.
	Imager is angled forward.	Slightly raise height of surface below front feet of imager.
The imager cannot read the cassette barcode.	If the cassette is valid, the barcode label may not be correctly positioned or the barcode reader window may be dirty.	Check the barcode label position and/or clean the barcode reader window. If this does not work, manually enter the barcode number (refer to the <i>Horizon User’s Manual</i> ).

**Table 9-4. Media Cassette and Ribbon Troubleshooting (cont.)**

<b>Problem</b>	<b>Possible Causes</b>	<b>Solutions</b>
The imager indicates that the barcode is invalid.	There is a problem with the cassette's barcode.	Contact your Codonics representative.
The imager indicates that the media is contaminated or that the sheet count has been exceeded.	Additional sheets were inserted into the supply cassette beyond what was originally packaged.	For quality control reasons, you cannot add sheets to a supply cassette.
	The printer has been jamming.	Perform general cleaning procedures (refer to the <i>Horizon User's Manual</i> ).
The imager indicates that media needs to be loaded.	A print job was received that requires a media type/size that is not currently loaded.	Load the appropriate cassette or purge the print queue to remove that job (refer to "Purging Print Jobs" on page 9-19).
	The cassette is loaded but not seated properly.	Reseat the cassette.
Imager does not recognize that cassette is present.	If the imager does not respond to having the cassette inserted in any of the slots, the software may not be operating properly.	Reboot the imager.
	Cassette sensors are dirty.	Clean the cassette sensors. Contact technical support for details.
	If only one slot is not working, that slot's cassette sensor may have failed.	Move the cassette to a different slot. Then contact technical support.
The imager indicates that a media supply cassette is not supported.	The imager does not support that media type/size option.	Contact your Codonics representative to purchase that media option.
The imager indicates that the receive trays must be inserted.	The receive trays are not installed, or are not seated properly.	Properly install the receive trays.
The control panel indicates that no ribbon is loaded, when a ribbon is loaded.	The ribbon currently loaded is not a Codonics ribbon.	You must use Codonics ribbon.
	Failed ribbon sensor.	Contact technical support.

**Table 9-4. Media Cassette and Ribbon Troubleshooting (cont.)**

<b>Problem</b>	<b>Possible Causes</b>	<b>Solutions</b>
Film calibration failed.	Film too light or too dark.	Try using another cassette, or move the cassette to another slot.
	The film is facing the wrong way.	Flip the top sheet of media upside down and repeat calibration. If calibration is successful, call technical support if you believe that all sheets in the cassette have been loaded upside down. For quality control reasons, media should never be reloaded into a cassette.
	A jam prevented the film from moving.	Check for and correct any sheet jams.
	There is a problem with the imager. For example, two films were picked at once, or the imager is outside its operating temperature.	Wearing rubber gloves, carefully fan the media. To help prevent sheets from sticking together, store cassettes upright (the way they come packed in their shipping boxes), not lying flat.  Make sure that the imager fan is working, and that the room is within the proper temperature and humidity operating ranges (refer to Appendix A for operating specifications).

**Table 9-5. Miscellaneous Troubleshooting**

<b>Problem</b>	<b>Possible Causes</b>	<b>Solutions</b>
Control panel displays "Invalid smart card."	Smart Card is not firmly seated.	Remove and insert the Smart Card.
	Incorrect Smart Card is inserted from another model imager.	Reinsert the imager's original Smart Card.
	Smart Card is damaged.	Contact technical support for a replacement.
Experiencing connection errors at console or workstation from which DICOM print jobs are sent.	Running DICOM Lite on imager, and need more connections than is provided by DICOM Lite.	Contact technical support about upgrading to full DICOM.

# Status Message Tables

## Common Cassette Status Messages

The following table lists the common cassette-related status messages.







**Table 9-6. Cassette Status Messages**

Message	Explanation
Barcode error	The supply cassette's barcode cannot be read.
Calibrating	The imager is performing a calibration.  When performing a film calibration (when a <b>DirectVista</b> grayscale film cassette is first inserted, or initiated manually through the Main Menu), the "calibrating" message toggles with supply information.
Checking cassette	The imager is reading the supply cassette's barcode, or waiting to read the barcode (for example, if the top cover is open, barcode will not be read).
Media contaminated	Imager believes the loaded cassette should have exhausted its media supply.
Media jam	A jam has occurred with media from the indicated cassette.
<i>Media size, type, and count</i>	Indicates the type, size, and sheet count of the media cassette inserted in the corresponding supply slot. For example, <b>14x17 DV Blue 53</b> , indicating the cassette currently has 53 sheets of 14 x 17-in. <b>DirectVista</b> blue film.
No cassette	No cassette is loaded in the supply slot.
Printing	The imager is printing from the indicated cassette.
Unsupported media	The media in a loaded supply cassette is not supported by the imager (for example, <b>ChromaVista</b> color film is loaded but that media option was not purchased with the imager).  Imager software is out of date.
Cleaning	The imager is cleaning the picking system.

## Color Ribbon Status

The following table lists the color ribbon status indications.

Table 9-7. Color Ribbon Status Indications

Indication	Explanation
	Blank; the imager supports only <b>DirectVista</b> grayscale media.
	Ribbon loaded. Ribbon type indicated ( <b>CMY</b> for cyan/magenta/yellow).
	Ribbon loaded but the ribbon is spent.
	Ribbon not loaded (and the imager does support <b>ChromaVista</b> color media).
	State of ribbon being determined.
	Ribbon loaded but in an error condition.

## Clearing a Sheet Jam

A sheet may occasionally get jammed in the imager. If this happens:

- The imager goes offline.
- A fault message displays.
- The area at which the jam occurred is indicated in the Status window.
- The **FAULT** indicator lights.
- An audible fault beep sounds.

- The imager pauses while the thermal print head cools, then partially pops open the top cover.

The message in the Status screen will be one of the following:

- **Clear jam from cassette X.** This message indicates that the sheet is:
  - Still in the cassette (possibly because the pick tires are dirty and could not grab the sheet).
  - Stuck in the lower part of the imager (refer to the figure on page 9-11).
- **Clear jam from the printing area.** This message indicates that the sheet has jammed while printing and is:
  - Stuck in the lower part of the imager.
  - Stuck in the upper part of the imager. The upper part of the imager includes the thermal print head/platen roller area, the capstan/pinch roller area, the diverter, and the receive trays.

The following figure shows the media path, and indicates the lower and upper parts of the imager.

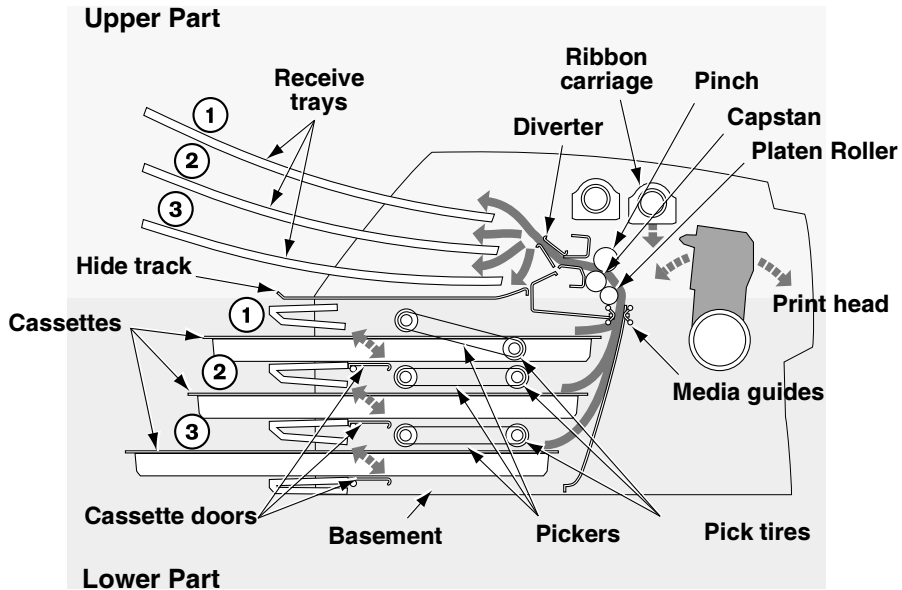

***Cross-Section of Imager, Showing Internal Media Path***

Clearing a jam from these likely locations is described in the following topics.

## Clearing a Jam from a Cassette



To clear a jam indicated by “Clear jam from cassette X”

1. Gently pull out the supply cassette indicated on the Status screen.
2. Check to see if the sheet is sticking out from the cassette or the supply slot.
  - *If the sheet is sticking out from the cassette or the supply slot, pull it out gently; then go to step 8.*
  - *If the sheet IS NOT sticking out from the cassette or the supply slot, go to the next step.*
3. Open the top cover (which has already been partially opened by the imager).



**WARNING** With the top cover open, touch only those internal components that are colored green (except for the pick tires, refer to the figure on page xx). Remove rings, ties, jewelry, and other items, and tie back hair, so that they do not fall into or get caught in the imager.

4. Remove the receive trays, as shown in the following figure.

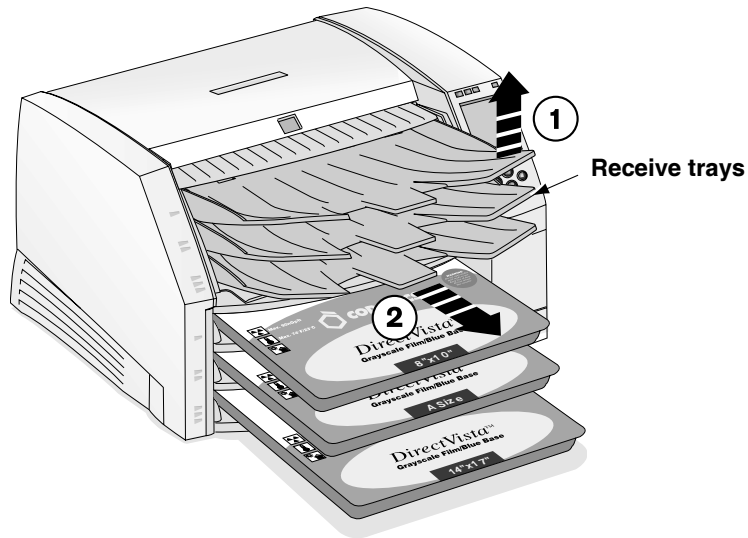



5. Place the receive trays on a flat surface, as shown in the following figure.

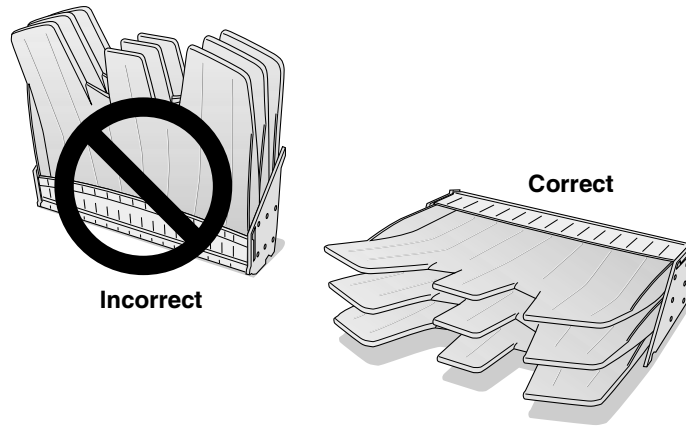

6. Remove all cassettes from the supply slots.
7. Look down into the imager to locate either the trailing or leading edge of the sheet:
  - *If you see the trailing edge in the lower part of the imager, lift the pickers (refer to the figure on page 9-11) and gently remove the sheet, or push the corresponding cassette flap down and feed the sheet back out the supply slot opening.*



**CAUTION** Do not touch the pick tires; body oils from your fingers are hard to remove and could eventually damage the tires.

- *If you see the leading edge in the upper part of the imager, gently pull the sheet out through the top of the imager.*



**CAUTION** To avoid damaging internal components, use care when removing a sheet from the media path in the upper part of the imager.

8. Discard the sheet.



**CAUTION** Never put a sheet back in the cassette. Dust or oil from your finger will affect the image quality.

9. If the top cover is open, close it.

After a few seconds, the Status screen displays and printing resumes if jobs are queued.

## Clearing a Jam from the Printing Area



**NOTE:** When a jam occurs, the imager disengages all motors to allow you to safely pull out the sheet.



To clear a jam indicated by “Clear jam from the printing area”

1. Open the top cover (which has already been partially opened by the imager).



**WARNING** With the top cover open, touch only those internal components that are colored green (except for the pick tires, refer to the figure on page xx). Remove rings, ties, jewelry, and other items, and tie back hair, so that they do not fall into or get caught in the imager.

2. Remove the receive trays, as shown in the following figure.

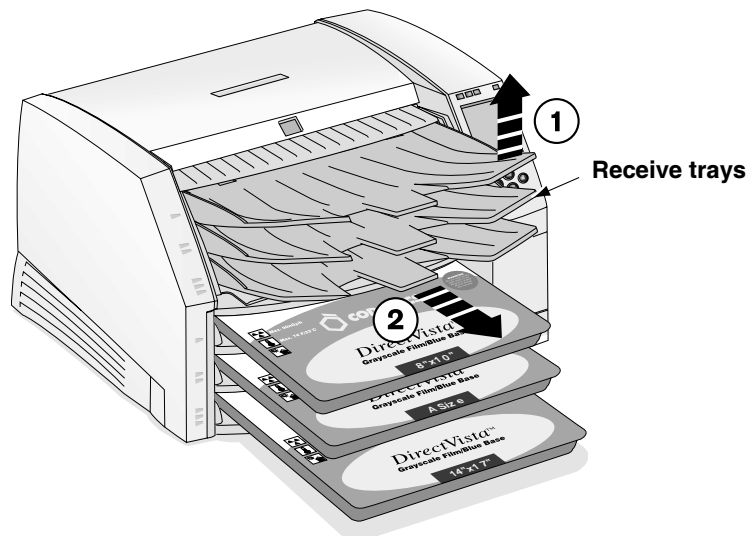

3. Place the receive trays on a flat surface, as shown in the following figure.

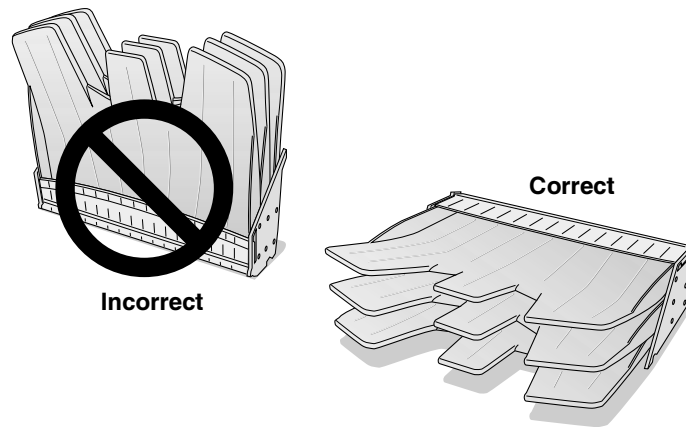

4. Remove all cassettes from the supply slots.
5. Check to see if the sheet is sticking out from one of the cassettes or supply slots.
  - *If the sheet is sticking out from one of the cassettes or supply slots, pull it out gently; then go to step 7.*
  - *If the sheet IS NOT sticking out from one of the cassettes or supply slots, go to the next step.*
6. Look down into the imager to locate either the trailing or leading edge of the sheet:
  - *If you see the trailing edge in the lower part of the imager, lift the pickers (refer to the figure on page 9-11) and gently remove the sheet, or push the corresponding cassette flap down and feed the sheet back out the supply slot opening.*



**CAUTION** Do not touch the pick tires; body oils from your fingers are hard to remove and could eventually damage the tires.

- *If you see the leading edge in the upper part of the imager, gently pull the sheet out through the top of the imager.*



**CAUTION** To avoid damaging internal components, use care when removing a sheet from the media path in the upper part of the imager.



**NOTE:** To access the jammed sheet, you may need to remove the ribbon and/or move the ribbon carriage down using the **Load/Remove Ribbon** option in the Open Top Cover menu.

- *If the leading edge is through the diverter, gently pull the sheet out through the diverter (refer to the figure on page 9-11).*

7. Discard the sheet.



**CAUTION** Never put a sheet back in the cassette. Dust or oil from your finger will affect the image quality.

8. If the top cover is open, close it.

After a few seconds, the Status screen displays and printing resumes if jobs are queued.

## Reinstalling Media Guides

When clearing sheet jams, the media guides could accidentally come out of their slots.

Media guides

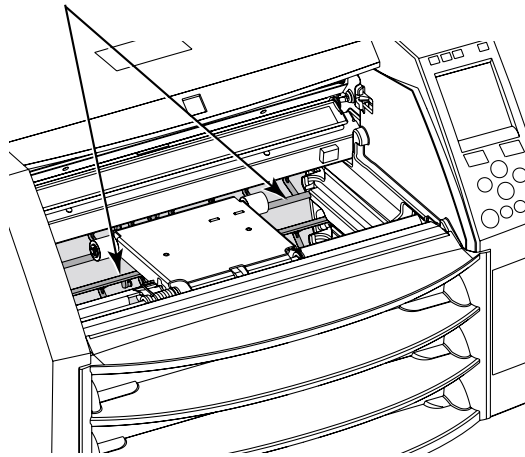

To reinstall the media guides

1. Slide the media guide into the imager through the cassette slots, as shown in the following figure.

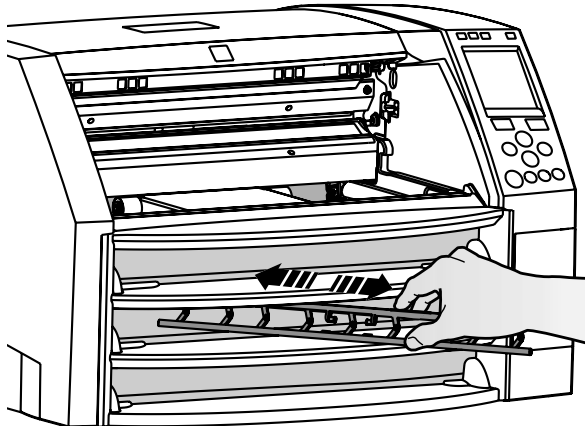

2. Insert the bottom leg of the media guide in both sides of the imager, as shown in the following figure.

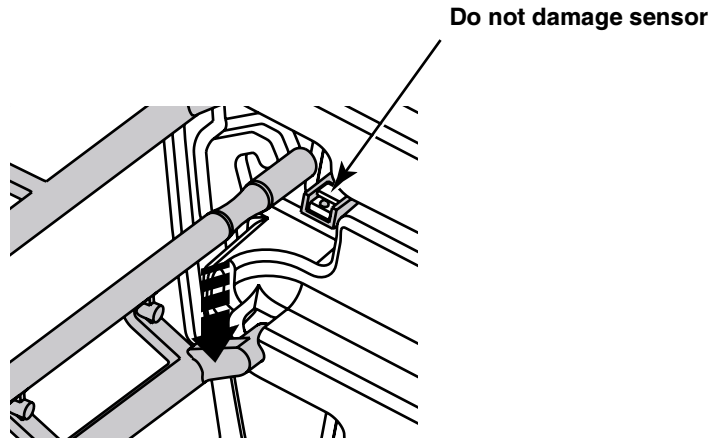

**CAUTION** Be careful not to scratch the polished sheet metal or damage the sensor near the upper guide notch.

3. Rotate the top leg into place, as shown below.

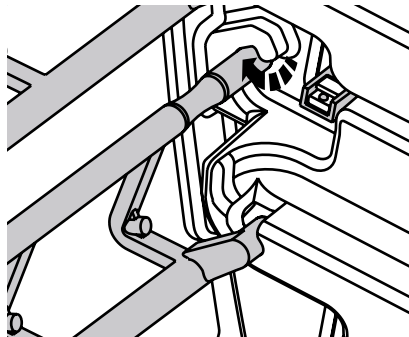



**CAUTION** Make sure you do not over-rotate the media guide, as shown below.

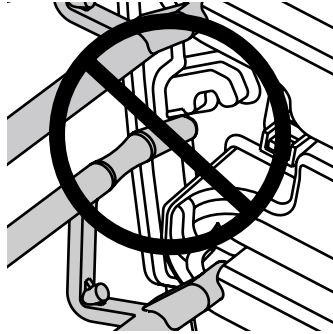

4. Repeat the procedure for the second media guide.

## Purging Print Jobs



To purge all  
queued print  
jobs

If necessary, you can purge all queued print jobs in the imager.

1. Press the **MENU** key.  
The Main Menu displays.
2. Select the following menu options:

**Utilities**  
**Purge Print Jobs**

You are prompted to confirm the purge operation.

3. To continue with the purge, press the **ENTER** key.  
All print jobs are purged, and the Utilities menu is displayed again.



**CAUTION** Use care when running the Purge Print Jobs function. This function will purge other users' print jobs as well as yours.

## **Contacting Technical Support**

For questions regarding your Horizon imager, please first refer to this manual, which describes the features and operations.

Technical assistance is available by phone at:

**Phone: +1.440.243.1198**

**Toll Free: 800.444.1198 (USA Only)**

Phone support is available 24 hours a day, 7 days a week.

Technical assistance is available on the web at:

**[www.codonics.com](http://www.codonics.com)**

When contacting Codonics for technical support, please have the following information on hand:

- The imager's serial number (on the back of the imager)
- The imager's license code (printed on the License Code Certificate which came with the imager, and on the imager's Smart Card)
- Any control panel status or error messages related to the problem



# A

## Specifications

Print Technology:	Dye-diffusion and direct thermal
Resolution:	319.5 dpi (12.6 pixels/mm)
Throughput:	Up to 100 films per hour
Grayscale Contrast Resolution:	12 bits (4096)
Color Resolution:	16.7 million colors, 256 levels each of cyan, magenta, and yellow
Media Inputs:	3 supply cassettes, up to 100 sheets each; 1 color ribbon
Media Outputs:	3 receive trays; 50-sheet capacity each
Media Sizes:	8 x 10-in. 11 x 14-in. 14 x 17-in. A-Size Paper A-4 Size Paper Horizon XL Only: 14x36-in. 14x51-in.
Media Types:	<b>DirectVista</b> film (blue and clear) <b>DirectVista</b> grayscale paper <b>ChromaVista</b> color film (optional) <b>ChromaVista</b> color paper (optional)
Dmax:	≥ 3.0 OD with <b>DirectVista</b> film
Archival:	≥ 20 years for <b>DirectVista</b> film when stored under ANSI extended-term storage conditions
Supply Cassettes:	All media is pre-packaged and factory-sealed.

Interfaces:	10/100 Base-T Ethernet (RJ-45) 10/100/1000 Base-T Ethernet (on some hardware variations) Serial diagnostic port UPS monitor port
Network Protocols:	Standard: FTP, LPR Optional: DICOM, Windows networking printing
Image Formats:	Standard: TIFF, GIF, PCX, BMP, PGM, PPM, XWD, JPEG, PNG, SGI (RGB), Sun Raster (RAS), Targa (TGA) Optional: DICOM, PostScript compatibility
Image Quality:	Automatic calibration using built-in densitometer
Image Control:	Contrast, Gamma, Medical Color Matching (MCM), Polarity, Rotate, Saturation, Scaling
Sheet Control:	Background, Border Fill, Captions, Coverage, Image Warning, Dmax, Dmin, Film View, Look-Up Tables (LUT)
Sheet Formatting:	Variable Multiformatting™ (VMF™), Fixed Multiformatting (FMF), 35mm Slidemaker™
Control Panel:	Large, backlit LCD display Status lights: Online, Alert, Fault, and Activity Power and menu navigation buttons
Processor:	Intel
Memory:	256-MB RAM
Hard Disk:	10 GB or greater (8 GB available for spooling)
Removable Disk:	100-MB Zip Disk for software upgrades
Smart Card:	16 KB or greater for storing configuration data
Power:	Universal Input: 100–120/230 V~ 50/60 Hz 600 W printing, 150 W idle
Weight:	35.8 kg (79 lbs)
Engine Dimensions:	36.8 cm H, 52.1 cm W, 61 cm L (14.5 in. H, 20.5 in. W, 24 in. L)
Environment:	<b>Operating:</b> Temperature: 15 to 30°C (59 to 86°F) Ambient temperature for maximum print speed: 22.2°C (72°F) Humidity: 10% to 80% noncondensing  <b>Storage:</b> Temperature: -22.2 to 50.6°C (-8 to 123°F) Humidity: 5% to 85% noncondensing

IEC 60601-1

Classification: Class I equipment, type ordinary IXPO, continuous with intermittent loading.

Laser Classification: Class 1 laser product according to IEC 60825-1 and 21 CFR 1040.10 and 1040.11.

UL, cUL 2601

Classification: Class 1 equipment, type ordinary IXPO, continuous with intermittent loading. Suitable for use in the U.S.A. on a center-tapped, 240-V, single-phase circuit.



**B**

## ***System Job Settings Files***

The table on the following pages lists the preconfigured System Job Settings files. There is a System Job Settings file for each possible media type and size. System Job Settings files contain only Media Type and Media Size parameters.

The DefaultGrayscale and DefaultColor system Job Settings files cause the imager to use the Default Medias set at the control panel.

System Job Settings File	Corresponding Use
DefaultGrayscale	Imager uses the media set for Grayscale in the Default Media menu at the control panel
DefaultColor	Imager uses the media set for Color in the Default Media menu at the control panel
8x10-dvf	8x10 <b>DirectVista</b> film (blue)
8x10-dvfb	8x10 <b>DirectVista</b> film (blue)
8x10-dvfc	8x10 <b>DirectVista</b> film (clear)
11x14-dvf	11x14 <b>DirectVista</b> film (blue)
11x14-dvfb	11x14 <b>DirectVista</b> film (blue)
11x14-dvp	11x14 <b>DirectVista</b> paper/white film
14x17-dvf	14x17 <b>DirectVista</b> film (blue)
14x17-dvfb	14x17 <b>DirectVista</b> film (blue)
14x17-dvfc	14x17 <b>DirectVista</b> film (clear)
14x17-dvp	14x17 <b>DirectVista</b> paper
14x36-dvf	14x36 <b>DirectVista</b> film (blue)
14x36-dvfb	14x36 <b>DirectVista</b> film (blue)
14x51-dvf	14x51 <b>DirectVista</b> film (blue)
14x51-dvfb	14x51 <b>DirectVista</b> film (blue)
a-dvp	A-size <b>DirectVista</b> paper
a-cvp	A-size <b>ChromaVista</b> paper
a4-dvp	A4-size <b>DirectVista</b> paper
a4-cvp	A4-size <b>ChromaVista</b> paper
priority-high	Sets print job priority to high
priority-medium	Sets print job priority to medium
priority-low	Sets print job priority to low
receive-1	Forces sheet output to receive tray 1

<b>System Job Settings File</b>	<b>Corresponding Use</b>
receive-2	Forces sheet output to receive tray 2
receive-3	Forces sheet output to receive tray 3
syngofilm	Special OEM-specific Job Settings





# Index

## Numerics

10/100 Base-T  
Ethernet hubs, 1-7

## A

Active indicator, 2-9  
activity indicator, connector panel, 2-2  
administrative menu options, 2-11, 6-3  
Alert indicator, 2-4, 2-9, 9-1  
arrow selector in menus, 2-10

## B

barcode  
"barcode error" message, 9-8  
barcode reader window  
cleaning schedule, 7-2  
base IP address for Horizon imager, 1-13  
basement, 1-5  
scratches, 1-5  
basic imager operations, 2-1 to 2-11  
break-off leaders, 3-6

## C

calibration  
"calibrating film" message, 2-5  
"calibrating" message, 9-8  
film calibration schedule, 7-2  
Called AE Titles  
Job Settings files, using to specify, 4-4

cancel print jobs, 9-19  
cassettes  
"checking cassettes" message, 2-5, 9-8  
"no cassette" message, 2-5, 9-8  
changing, 3-4 to 3-5  
clearing a jam, 9-12  
loading media, 1-15  
media, 3-1 to 3-10  
status messages, 2-5, 9-8  
supply slots, 3-2  
troubleshooting, 9-5  
Category 5, RJ-45 cables, 1-7  
changing a supply cassette, 3-4 to 3-5  
ChromaVista color media  
break-off leaders, 3-6  
changing the ribbon, 3-7 to 3-9  
destroying the ribbon, 3-9  
ribbon status indications, 2-6, 9-9  
types and sizes, 3-10  
use precautions, -xxii  
cleaning kits  
ordering, 7-2  
cleaning precautions, -xxii  
CMY indicator, 2-4  
CNFG (configuration) label, -xvi  
Codonics  
email address, -x  
phone numbers, -x, 7-2  
product information, -x  
technical support, 9-20  
web site, 7-2  
color management  
precautions, -xxiv  
color ribbon  
status indications, 2-6, 9-9  
troubleshooting, 9-5  
compliance label, -xv

- location, -xii
- components, safe to touch, -xx
- confidentiality, patient, 3-9
- configuration number, -xvi
- connecting the imager, 2-2
- connectors, 2-2
- console connector, 2-2
- control panel
  - illustration, 2-8
  - imager operating status, 9-1
  - indicators, 2-9
- conventions used in this manual, -vii to -ix
- crossover cable, 1-8
- Custom Job Settings files, 4-4

## **D**

- date code, -xvi
- default print job settings, 6-1 to 6-3
- Default User Settings
  - changing, 6-3
- DefaultColor Job Settings file, B-2
- DefaultGrayscale Job Settings file, B-2
- delete print jobs, 9-19
- DICOM
  - conformance statement, 4-2
  - definition, 4-1
- DICOM applications
  - configuring, 4-2
  - printing from, 4-1 to 4-5
  - specifying media type and size, 4-3
- DirectVista grayscale media
  - film calibration, 8-1
  - types and sizes, 3-10
  - use precautions, -xxii
- disposal requirements, -xi
- donor guide bar
  - cleaning, 7-3 to 7-6
  - cleaning schedule, 7-1

## **E**

- electronic emissions notices, -xviii
- error log, 9-1
- ESD
  - caution, -xvii

- label, -xvii
- Ethernet
  - cable jack, 1-7
  - connecting cable, 1-6
  - crossover cable, 1-8, 1-10
  - hub, 1-7, 1-8, 1-10
- European disposal requirements, -xi
- expansion slot, 2-2

## **F**

- Fault indicator, 2-4, 2-9, 9-1
- Fault tone, 2-10
- file transfer
  - precautions, -xxiv
- film
  - path through imager, 9-11
  - see also* media
- film calibration, 8-1
  - schedule, 7-2
- film jams
  - clearing, 9-9 to 9-16
  - troubleshooting, 9-4
- front panel, *see* control panel
- FTP
  - file transfer precautions, -xxiv

## **H**

- hardware variations
  - precautions, -xxv
- help
  - message area, 2-10
  - troubleshooting information, 9-1
- hide track, 1-5
- Horizon imager
  - adding to a simple network, 1-10
  - base IP address, 1-13
  - basement, 1-5
  - basic operations, 2-1 to 2-11
  - changing default media type and size, 6-2
  - changing Default User Settings, 6-3
  - changing PostScript parameters in Windows, 5-2 to 5-4
  - cleaning precautions, -xxii
  - color management precautions, -xxiv

compliance, -xv  
 configuration number, -xvi  
 date code, -xvi  
 default print job settings, 6-1 to 6-3  
 disposal requirements, -xi  
 electronic emissions notices, -xviii  
 error log, 9-1  
 file transfer precautions, -xxiv  
 film calibration, 8-1  
 front view, 2-1  
 hardware variations precautions, -xxv  
 hide track, 1-5  
 hierarchy of print job settings, 4-5  
 image scaling precautions, -xxiv  
 indications for use, -xxv  
 installing, 1-2 to 1-6  
 internal components safe to touch, -xx  
 laser warnings, -xiv  
 location precautions, -xxi  
 media use precautions, -xxii  
 modification codes, -xvi  
 online help, 9-1  
 operational state indicators, 2-4  
 packaging, 1-2  
 power key, 2-3  
 powering off, 2-7  
 powering on, 2-3  
 powering on for first time, 1-8  
 preparing for installation, 1-1  
 preparing for shipment, 1-15  
 preventive maintenance, 7-1 to 7-9  
 rear connectors, 2-2  
 rear view, 2-2  
 safety precautions, -xix  
 serial number label, -xvi  
 specifications, A-1 to A-3  
 specifying IP addresses, 1-11 to 1-14  
 technical support, 9-20  
 temperature warnings, -xv  
 troubleshooting, 9-1 to 9-20  
 voltage warnings, -xiii  
 hubs, Ethernet, 1-7

## I

image scaling  
   precautions, -xxiv  
 images

  quality troubleshooting, 9-5  
 indications for use of the imager, -xxv  
 indicators  
   Alert, 2-4, 9-1  
   CMY, 2-4  
   color ribbon status, 2-6, 9-9  
   control panel, 2-9  
   Fault, 2-4, 9-1  
   network activity, 2-2  
   network speed, 2-2  
   OK, 2-4  
   ribbon, 2-4  
 installation  
   preparing for, 1-1  
 interference, radio and television, -xviii  
 internal components safe to touch, -xx  
 IP addresses  
   format, 1-11  
   Horizon base address, 1-13  
   specifying for Horizon imager, 1-11 to 1-14  
   specifying for other devices on the network, 1-14

## J

jams  
   clearing, 9-9 to 9-16  
   troubleshooting, 9-4  
 Job Settings files  
   custom, 4-4  
   system, 4-4, B-1 to B-2

## K

keys  
   control panel, -viii

## L

laser warnings, -xiv  
 leaders, ChromaVista color media, 3-6  
 LEDs, *see* indicators  
 license code  
   where found, 9-20  
 loading cassettes, 3-4 to 3-5  
 loading media, 3-4 to 3-5

- loading ribbon, 3-7 to 3-9
- local area networks (LAN), 1-10
- location precautions, -xxi
- log files
  - error log, 9-1
- LPR
  - file transfer precautions, -xxiv

## **M**

- Main Menu, 2-10
  - displaying administrative options, 2-11, 6-3
- maintenance
  - recommended schedule, 7-1
- media
  - "calibrating film" message, 2-5
  - "calibrating" message, 9-8
  - "checking cassette" message, 2-5, 9-8
  - "cleaning" message, 9-8
  - "media contaminated" message, 9-8
  - "media jam" message, 9-8
  - "no cassette" message, 2-5, 9-8
  - "printing" message, 2-5, 9-8
  - "unsupported media" message, 9-8
  - break-off leaders for ChromaVista color media, 3-6
  - cassette-related messages, 2-5, 9-8
  - cassettes, 3-1 to 3-10
  - changing default size and type, 6-2
  - handling and storage, 3-1 to 3-10
  - loading cassettes, 1-15
  - ordering, 3-10
  - path through imager, 9-11
  - selecting from Windows applications, 5-4
  - setting type and size via DICOM, 4-3
  - size, type, and count status message, 2-5, 9-8
  - supply slots, 3-2
  - troubleshooting cassettes, 9-5
  - troubleshooting jams, 9-4
  - types and sizes, 3-10
  - use precautions, -xxii
- media guides, reinstalling, 9-17
- menu options
  - control panel, -viii
- menu paths, -viii
- menus
  - scroll indicator, 2-11
- misfeeds, 9-9 to 9-16

- modem connectors, 2-2
- modification codes, -xvi

## **N**

- network activity indicator, 2-2
- network connector, 1-7, 2-2
- network speed indicator, 2-2
- networks
  - adding the Horizon imager, 1-10
  - simple, 1-10
- nosepiece
  - cleaning, 7-3 to 7-6
  - cleaning schedule, 7-1

## **O**

- OK indicator, 2-4
- Online indicator, 2-9
- operational state, 2-4
- ordering cleaning kits, 7-2
- ordering media, 3-10

## **P**

- packing the imager, 1-15
- paper
  - path through imager, 9-11
  - see also* media
- paper jams
  - clearing, 9-9 to 9-16
  - troubleshooting, 9-4
- parts safe to touch, -xx
- patch cable, 1-8
- patient confidentiality, 3-9
- pick tires
  - cleaning, 7-7 to 7-9
  - cleaning schedule, 7-1
- platen
  - cleaning, 7-3 to 7-6
  - cleaning schedule, 7-1
- Platen and Print Head Cleaning Kit, 7-2
- PostScript
  - changing parameters from Windows, 5-2 to 5-4
  - introduction, 5-2

- printing from Windows applications, 5-1 to 5-4
- power key, 2-3
- Power menu, bypassing, 2-7
- power rocker switch, 1-8
- powering off the Horizon imager, 2-7
- powering on for first time, 1-8
- powering on the Horizon imager, 2-3
- precautions
  - cleaning, -xxii
  - color management, -xxiv
  - file transfer via FTP and LPR, -xxiv
  - hardware variations, -xxv
  - image scaling, -xxiv
  - location, -xxi
  - media use, -xxii
  - safety, -xix
- preventive maintenance, 7-1 to 7-9
  - recommended schedule, 7-1
- print jobs
  - purging, 9-19
- print parameters
  - default settings, 6-1 to 6-3
- print quality problems, 9-5
- printing
  - from DICOM applications, 4-1 to 4-5
  - troubleshooting, 9-2
- purge print jobs, 9-19
- purpose of Starter Manual, -ix

## Q

- quality problems with prints, 9-5

## R

- radio interference, -xvii, -xviii
- recycling requirements, -xi
- removing jams, 9-9 to 9-16
- returning the imager to Codonics, 1-15
- ribbon
  - changing, 3-7 to 3-9
  - destroying, 3-9
  - indicator, 2-4
  - loading, 1-15
- RJ-45 cables, Category 5, 1-7

## S

- safety
  - internal components, safe to touch, -xx
  - location of labels, -xii
  - precautions, -xix
- scratches
  - on imager basement, 1-5
  - on sheet, 9-5
- scroll indicator in menus, 2-11
- selector arrow in menus, 2-10
- serial number
  - where found, 9-20
- serial number label, -xvi
- settings
  - print jobs, defaults, 6-1 to 6-3
- sheet jams
  - clearing, 9-9 to 9-16
  - troubleshooting, 9-4
- sheets
  - path through imager, 9-11
- shipping the imager, 1-15
- simple network
  - with Ethernet crossover cable, 1-11
  - with Ethernet hub, 1-10
- specifications, A-1 to A-3
- speed indicator, connector panel, 2-2
- Starter Manual, purpose, -ix
- startup
  - troubleshooting, 9-2
- status
  - cassette-related messages, 2-5, 9-8
  - color ribbon indicator, 2-6, 9-9
- Status screen
  - description, 2-4
- Status window
  - Alert messages, 2-10
  - description, 2-4
  - Fault messages, 2-10
- supply cassettes, *see* cassettes
- supply slots, 3-2
  - status, 3-3
- Supply window, description, 2-4
- System Job Settings files, 4-4, B-1 to ??
- system Job Settings files, ?? to B-2

## **T**

- technical support, 9-20
- television interference, -xviii
- temperature warnings, -xv
- thermal print head
  - cleaning, 7-3 to 7-6
  - cleaning schedule, 7-1
- troubleshooting, 9-1 to 9-20
  - cassettes, 9-5
  - color ribbon, 9-5
  - image quality, 9-5
  - miscellaneous, 9-7
  - print jobs, 9-2
  - sheet jams, 9-4
  - startup, 9-2
- turning off the imager, 2-7
- turning on the imager, 2-3

## **U**

- unshielded twisted pair (UTP) cable, 1-7
- UPS (uninterruptible power supply), 1-3
- UPS connector, 2-2
- use of the imager, indications for, -xxv

## **V**

- voltage warnings, -xiii

## **W**

- warnings
  - laser, -xiv
  - temperature, -xv
  - voltage, -xiii
- WEEE disposal requirements, -xi
- wide area networks (WAN), 1-10
- Windows applications
  - changing PostScript parameters, 5-2 to 5-4
  - PostScript printing from, 5-1 to 5-4